

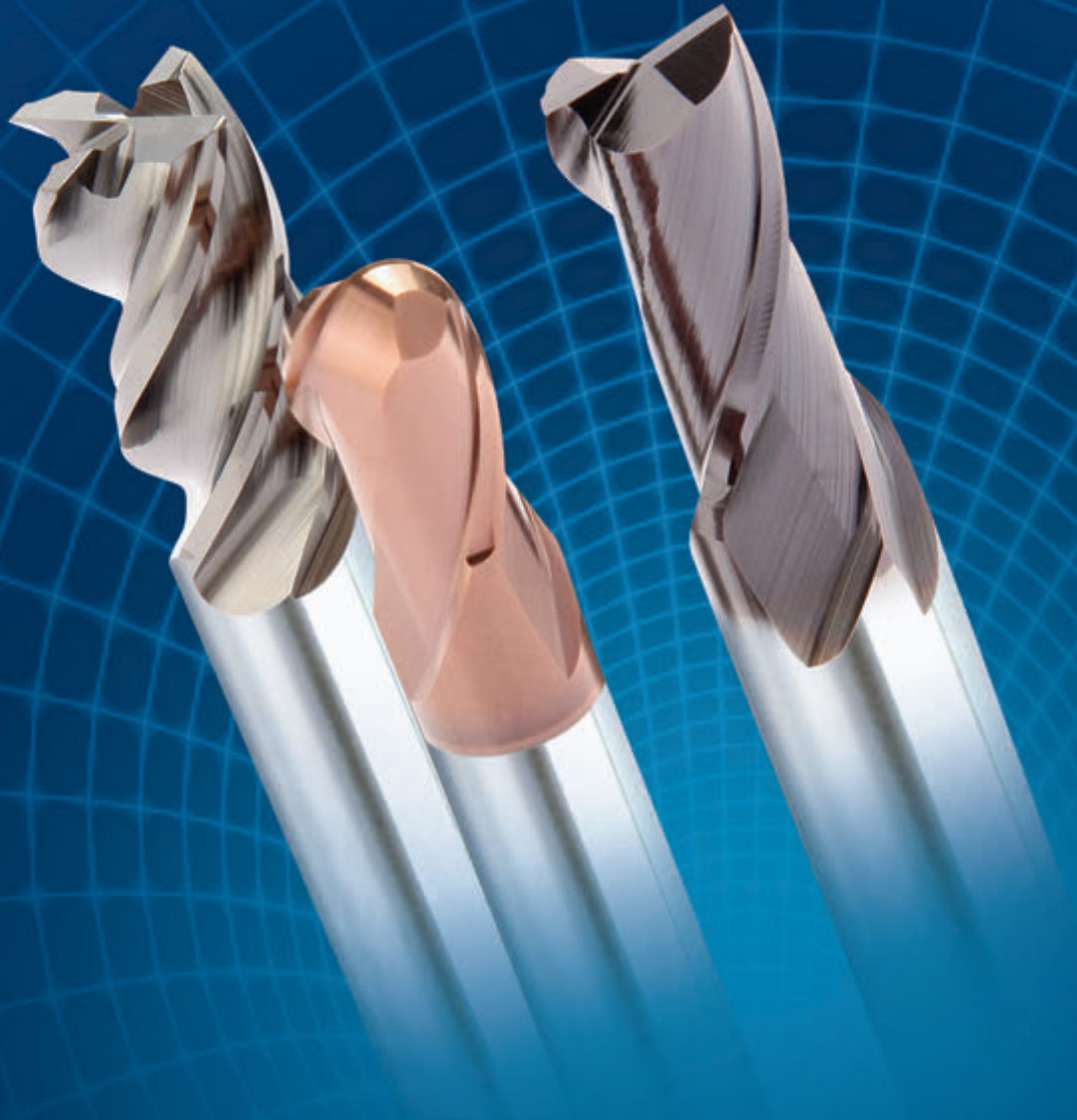























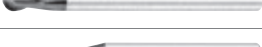
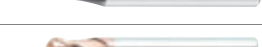









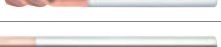

# KARBÜR PARMAK FREZELER



# İÇİNDEKİLER

		MIN ~ MAX	SAYFA		
GS		GS-EBD	R0,05~R12,5	4	
		GS-LS-EBD	R0,5~R10	5	
		GS-LN-EBD	R0,05~R2	6-9	
		GS-EDS	$\Phi$ 0,1~ $\Phi$ 25	10-11	
		GS-EDL	$\Phi$ 1~ $\Phi$ 25	12	
		GS-CR-EDS	$\Phi$ 1~ $\Phi$ 16	13-15	
		GS-LN-EDS	$\Phi$ 0,1~ $\Phi$ 4	16-18	
		GS-LN-CR-EDS	$\Phi$ 0,8~ $\Phi$ 12	19-22	
		GS-EMS	$\Phi$ 1~ $\Phi$ 25	23	
		GS-EML	$\Phi$ 2~ $\Phi$ 25	24	
		GS-CR-EMS	$\Phi$ 1~ $\Phi$ 16	25-27	
		GS-RESF	$\Phi$ 6~ $\Phi$ 12	28	
AL		AL+MG-ET	$\Phi$ 1~ $\Phi$ 20	30-32	
		AL+MG-ED	$\Phi$ 1~ $\Phi$ 20	33	
		AL+MG-REE	$\Phi$ 6~ $\Phi$ 20	34	
		CRN-LN-EDS	$\Phi$ 0,5~ $\Phi$ 4	36	
		CRN-LN-CR-EDS	$\Phi$ 2~ $\Phi$ 12	37	
		CRN-EBD	R0,25~R6	38	
CRN		CRN-LN-EBD	R0,25~R2	39	
		WS-EBD	R0,05~R6	41	
WS		WS-EBDS	R0,05~R6	42	
		WS-LN-EBD	R0,05~R6	43-45	
		WS-LN-EBD-6	R0,3~R1,0	46	
		WS-EDS	$\Phi$ 0,1~ $\Phi$ 12	47	
		WS-LN-EDS	$\Phi$ 0,1~ $\Phi$ 4	48-50	
		WS-EMS	$\Phi$ 1~ $\Phi$ 12	51	
		WS-LN-EMS	$\Phi$ 2~ $\Phi$ 12	52	
		WS-LN-CR-EDS	$\Phi$ 1~ $\Phi$ 12	53-58	
		WS-LN-CR-EMS	$\Phi$ 2~ $\Phi$ 12	59-60	
		WS-PHS	$\Phi$ 3~ $\Phi$ 20	61	
		WS-PKE	$\Phi$ 3~ $\Phi$ 12	61	
		WS-LS-PKE	$\Phi$ 4~ $\Phi$ 12	62	
		WS-CRE	$\Phi$ 2~ $\Phi$ 12	62	
	SUS		S-VCM	$\Phi$ 3~ $\Phi$ 12	64
			SUS-PMS	$\Phi$ 3~ $\Phi$ 12	65
			SUS-CR-PMS	$\Phi$ 3~ $\Phi$ 12	66

# GS SERİLERİ

- Karbür Freze
- 60 HRC'ye kadar sertleştirilmiş çelikler ve paslanmaz çelik için



# GS-EBD

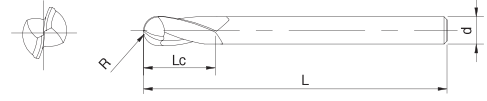

EDP No.	R	L	Lc	d	fiyat \$
GS9528001K	R0,05	40	0,2	4	54,66
GS9528002K	R0,1	50	0,4	4	37,41
GS9528004K	R0,2	50	0,8	4	30,59
GS9528005K	R0,25	50	1,1	4	26,34
GS9528006K	R0,3	50	1,1	4	26,34
GS9528007K	R0,35	50	1,5	4	26,34
GS9528008K	R0,4	50	2	4	26,34
GS9528009K	R0,45	50	2,2	4	26,34
GS9528010K	R0,5	50	2,5	6	24,91
GS9528015K	R0,75	50	4	6	24,91
GS9528020K	R1	50	5	6	24,91
GS9528025K	R1,25	60	6	6	25,88
GS9528030K	R1,5	60	8	6	25,88
GS9528040K	R2	70	8	6	26,97
GS9528050K	R2,5	80	10	6	27,94
GS9528060K	R3	90	12	6	29,16
GS9528070K	R3,5	90	14	6	46,75
GS9528080K	R4	100	14	8	46,75
GS9528090K	R4,5	100	18	8	60,25
GS9528100K	R5	100	18	10	60,25
GS9528110K	R5,5	100	22	10	82,94
GS9528120K	R6	110	22	12	82,94
GS9521130K	R6,5	110	26	12	131,03
GS9521140K	R7	110	26	12	141,84
GS9521150K	R7,5	110	30	12	182,69
GS9521160K	R8	140	30	16	193,97
GS9521180K	R9	140	34	16	248,03
GS9521200K	R10	160	38	20	284,69
GS9521250K	R12,5	180	50	25	497,91

- Küresel karbür freze
- 60 HRC'ye kadar sertleştirilmiş çelikler için



# GS-LS-EBD

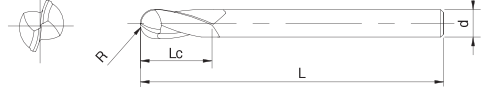

EDP No.	R	L	Lc	d	fiyat \$
GS9628010K	R0,5	70	2,5	6	30,59
GS9628012K	R0,5	100	2,5	6	37,06
GS9628015K	R0,75	70	4	6	30,59
GS9628017K	R0,75	100	4	6	37,06
GS9628020K	R1	75	5	6	31,75
GS9628022K	R1	100	5	6	37,06
GS9628025K	R1,25	75	6	6	32,94
GS9628027K	R1,25	100	6	6	37,38
GS9628030K	R1,5	80	8	6	33,72
GS9628032K	R1,5	100	8	6	37,38
GS9628040K	R2	90	8	6	36,09
GS9628042K	R2	120	8	6	43,13
GS9628060K	R3	100	12	6	37,38
GS9628062K	R3	120	12	6	44,34
GS9628080K	R4	130	14	8	57,22
GS9628082K	R4	150	14	8	66,91
GS9628100K	R5	150	18	10	94,44
GS9628102K	R5	180	18	10	120,25
GS9628120K	R6	150	22	12	115,00
GS9628122K	R6	200	22	12	164,66
GS9628160K	R8	160	30	16	231,25
GS9628162K	R8	200	30	16	304,22
GS9628200K	R10	200	38	20	417,38

- Küresel karbür freze
- 60 HRC'ye kadar sertleştirilmiş çelikler için
- Uzun boylu seri

# GS-LN-EBD

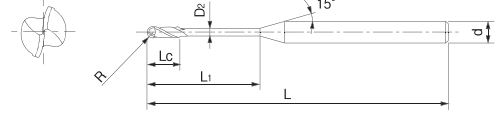

EDP No.	D	L	R	Lc	d	fiyat \$
GS3130101K	R0,05	45	0,3	0,1	4	56,09
GS3130102K	R0,05	45	0,5	0,1	4	56,09
GS3130201K	R0,1	45	0,5	0,16	4	41,88
GS3130202K	R0,1	45	1	0,16	4	41,88
GS3130203K	R0,1	45	1,5	0,16	4	41,88
GS3130204K	R0,1	45	2	0,16	4	39,38
GS3130302K	R0,15	45	1	0,24	4	39,38
GS3130303K	R0,15	45	1,5	0,24	4	39,38
GS3130304K	R0,15	45	2	0,24	4	39,38
GS3130305K	R0,15	45	3	0,24	4	39,38
GS3130306K	R0,15	45	4	0,24	4	39,38
GS3130307K	R0,15	45	5	0,24	4	37,88
GS3130402K	R0,2	45	1	0,3	4	37,88
GS3130403K	R0,2	45	1,5	0,3	4	37,88
GS3130404K	R0,2	45	2	0,3	4	37,88
GS3130405K	R0,2	45	2,5	0,3	4	37,88
GS3130406K	R0,2	45	3	0,3	4	37,88
GS3130407K	R0,2	45	4	0,3	4	37,88
GS3130408K	R0,2	45	5	0,3	4	37,88
GS3130409K	R0,2	45	6	0,3	4	37,88
GS3130410K	R0,2	45	8	0,3	4	37,88
GS3130411K	R0,2	45	10	0,3	4	37,88
GS3130502K	R0,25	45	2	0,4	4	34,63
GS3130503K	R0,25	45	3	0,4	4	34,63
GS3130504K	R0,25	45	4	0,4	4	34,63
GS3130505K	R0,25	45	5	0,4	4	35,63
GS3130506K	R0,25	45	6	0,4	4	35,63
GS3130508K	R0,25	45	8	0,4	4	35,63
GS3130510K	R0,25	45	10	0,4	4	35,63
GS3130512K	R0,25	50	12	0,4	4	35,63
GS3130602K	R0,3	45	2	0,5	4	32,47
GS3130603K	R0,3	45	3	0,5	4	32,47
GS3130604K	R0,3	45	4	0,5	4	32,47
GS3130605K	R0,3	45	5	0,5	4	32,47
GS3130606K	R0,3	45	6	0,5	4	32,47

- Küresel karbür freze
- Boyunlu karbür freze
- 60 HRC'ye kadar sertleştirilmiş çelikler için

# GS-LN-EBD

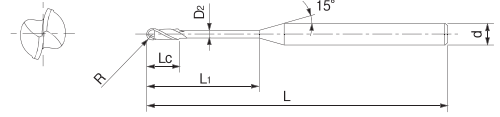

EDP No.	D	L	R	Lc	d	fiyat \$
GS3130608K	R0,3	45	8	0,5	4	33,47
GS3130610K	R0,3	45	10	0,5	4	33,47
GS3130612K	R0,3	50	12	0,5	4	33,47
GS3130614K	R0,3	50	14	0,5	4	33,47
GS3130702K	R0,35	45	2	0,6	4	34,09
GS3130704K	R0,35	45	4	0,6	4	34,09
GS3130706K	R0,35	45	6	0,6	4	34,09
GS3130708K	R0,35	45	8	0,6	4	34,09
GS3130710K	R0,35	45	10	0,6	4	34,09
GS3130802K	R0,4	45	2	0,6	4	30,34
GS3130804K	R0,4	45	4	0,6	4	30,34
GS3130805K	R0,4	45	5	0,6	4	30,34
GS3130806K	R0,4	45	6	0,6	4	30,34
GS3130807K	R0,4	45	7	0,6	4	30,34
GS3130808K	R0,4	45	8	0,6	4	30,34
GS3130810K	R0,4	45	10	0,6	4	30,34
GS3130812K	R0,4	45	12	0,6	4	30,34
GS3130814K	R0,4	50	14	0,6	4	30,34
GS3131002K	R0,5	45	2,5	0,8	4	26,97
GS3131003K	R0,5	45	3	0,8	4	26,97
GS3131004K	R0,5	45	4	0,8	4	26,97
GS3131005K	R0,5	45	5	0,8	4	26,97
GS3131006K	R0,5	45	6	0,8	4	26,97
GS3131007K	R0,5	45	7	0,8	4	26,97
GS3131008K	R0,5	45	8	0,8	4	26,97
GS3131009K	R0,5	45	9	0,8	4	28,09
GS3131010K	R0,5	45	10	0,8	4	28,09
GS3131012K	R0,5	45	12	0,8	4	28,09
GS3131014K	R0,5	50	14	0,8	4	28,09
GS3131016K	R0,5	50	16	0,8	4	28,09
GS3131020K	R0,5	55	20	0,8	4	28,09
GS3131206K	R0,6	45	6	1	4	28,09
GS3131208K	R0,6	45	8	1	4	28,09
GS3131210K	R0,6	45	10	1	4	28,09
GS3131212K	R0,6	45	12	1	4	28,09

# GS-LN-EBD

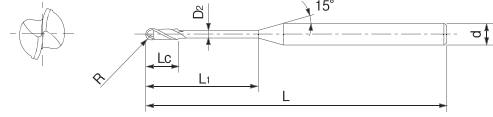

EDP No.	D	L	R	Lc	d	fiyat \$
GS3131214K	R0,6	50	14	1	4	28,09
GS3131216K	R0,6	50	16	1	4	28,09
GS3131220K	R0,6	55	20	1	4	28,09
GS3131306K	R0,7	45	6	1,2	4	28,09
GS3131308K	R0,7	45	8	1,2	4	28,09
GS3131312K	R0,7	50	12	1,2	4	28,09
GS3131316K	R0,7	50	16	1,2	4	28,09
GS3131503K	R0,75	45	3	1,2	4	26,97
GS3131504K	R0,75	45	4	1,2	4	26,97
GS3131506K	R0,75	45	6	1,2	4	26,97
GS3131508K	R0,75	45	8	1,2	4	26,97
GS3131510K	R0,75	45	10	1,2	4	28,09
GS3131512K	R0,75	45	12	1,2	4	28,09
GS3131516K	R0,75	50	16	1,2	4	28,09
GS3131520K	R0,75	55	20	1,2	4	28,09
GS3131525K	R0,75	60	25	1,2	4	28,97
GS3131530K	R0,75	65	30	1,2	4	33,97
GS3132004K	R1	45	4	1,6	4	26,97
GS3132005K	R1	45	5	1,6	4	26,97
GS3132006K	R1	45	6	1,6	4	26,97
GS3132008K	R1	45	8	1,6	4	26,97
GS3132010K	R1	45	10	1,6	4	26,97
GS3132012K	R1	45	12	1,6	4	26,97
GS3132014K	R1	50	14	1,6	4	26,97
GS3132016K	R1	50	16	1,6	4	26,97
GS3132018K	R1	55	18	1,6	4	26,97
GS3132020K	R1	55	20	1,6	4	28,97
GS3132022K	R1	60	22	1,6	4	28,97
GS3132025K	R1	65	25	1,6	4	28,97
GS3132030K	R1	70	30	1,6	4	33,97
GS3135010K	R1,25	45	10	2	4	28,09
GS3135012K	R1,25	45	12	2	4	28,09
GS3135016K	R1,25	50	16	2	4	28,09
GS3135020K	R1,25	55	20	2	4	28,09
GS3133008K	R1,5	50	8	2,4	6	31,22



# GS-LN-EBD

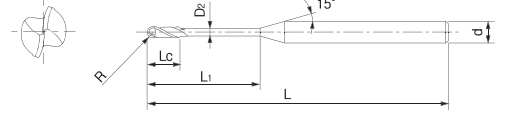

EDP No.	D	L	R	Lc	d	fiyat \$
GS3133010K	R1,5	50	10	2,4	6	31,22
GS3133012K	R1,5	50	12	2,4	6	31,22
GS3133016K	R1,5	55	16	2,4	6	32,84
GS3133020K	R1,5	60	20	2,4	6	32,84
GS3133025K	R1,5	65	25	2,4	6	34,84
GS3133030K	R1,5	70	30	2,4	6	39,88
GS3133035K	R1,5	80	35	2,4	6	43,75
GS3133040K	R1,5	90	40	2,4	6	45,97
GS3133045K	R1,5	90	45	2,4	6	45,97
GS3133050K	R1,5	100	50	2,4	6	50,34
GS3134008K	R2	60	8	3,2	6	31,22
GS3134010K	R2	60	10	3,2	6	31,22
GS3134012K	R2	60	12	3,2	6	31,22
GS3134016K	R2	60	16	3,2	6	32,84
GS3134020K	R2	65	20	3,2	6	32,84
GS3134025K	R2	70	25	3,2	6	34,84
GS3134030K	R2	80	30	3,2	6	39,88
GS3134035K	R2	80	35	3,2	6	43,75
GS3134040K	R2	90	40	3,2	6	47,78
GS3134045K	R2	90	45	3,2	6	50,41
GS3134050K	R2	100	50	3,2	6	54,41

# GS-EDS

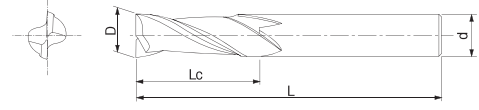

EDP No.	D	L	Lc	d	fiyat \$
GS9619001K	0.1	40	0.2	4	28,41
GS9619002K	0.2	40	0.4	4	28,41
GS9619003K	0.3	40	0.6	4	21,75
GS9619004K	0.4	40	0.8	4	21,75
GS9619005K	0.5	40	1	4	19,78
GS9619006K	0.6	40	1.2	4	19,78
GS9619007K	0.7	40	1.4	4	19,78
GS9619008K	0.8	40	1.6	4	19,78
GS9619009K	0.9	40	2	4	19,78
GS9519010K	1	40	2.5	6	18,69
GS9619010K	1	40	2.5	4	18,69
GS9619011K	1.1	40	2.5	4	18,69
GS9619012K	1.2	40	4	4	18,69
GS9619013K	1.3	40	4	4	18,69
GS9619014K	1.4	40	4	4	18,69
GS9519015K	1.5	40	4	6	18,69
GS9619015K	1.5	40	4	4	18,69
GS9619016K	1.6	40	5	4	18,69
GS9619017K	1.7	40	5	4	18,69
GS9619018K	1.8	40	5	4	18,69
GS9619019K	1.9	40	5	4	18,69
GS9519020K	2	40	6	6	18,69
GS9619020K	2	40	6	4	18,69
GS9619021K	2.1	40	6	4	18,69
GS9619022K	2.2	40	6	4	18,69
GS9619023K	2.3	40	6	4	18,69
GS9619024K	2.4	40	8	4	18,69
GS9519025K	2.5	40	8	6	18,69
GS9619025K	2.5	40	8	4	18,69
GS9619026K	2.6	40	8	4	18,69
GS9619027K	2.7	40	8	4	18,69
GS9619028K	2.8	40	8	4	18,69
GS9619029K	2.9	40	8	4	18,69
GS9519030K	3	45	8	6	18,69
GS9519035K	3.5	45	10	6	18,69

- 2 Ağızlı düz karbür freze
- 60 HRC'ye kadar sertleştirilmiş çelikler için

# GS-EDS

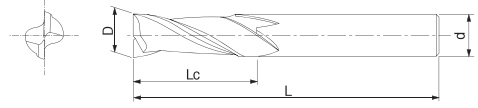

EDP No.	D	L	Lc	d	fiyat \$
GS9519040K	4	45	11	6	18,69
GS9519045K	4,5	45	11	6	18,69
GS9519050K	5	50	13	6	19,44
GS9519055K	5,5	50	13	6	19,44
GS9519060K	6	50	13	6	19,44
GS9619060K	6	60	15	6	19,44
GS9519065K	6,5	60	16	8	31,81
GS9519070K	7	60	16	8	31,81
GS9519075K	7,5	60	16	8	31,81
GS9519080K	8	60	19	8	33,28
GS9619080K	8	70	20	8	33,28
GS9519085K	8,5	70	19	10	44,47
GS9519090K	9	70	19	10	44,47
GS9519095K	9,5	70	19	10	44,47
GS9519100K	10	70	22	10	43,72
GS9619100K	10	75	25	10	43,72
GS9519105K	10,5	75	22	12	55,88
GS9519110K	11	75	22	12	55,88
GS9519120K	12	75	26	12	56,09
GS9619120K	12	80	30	12	56,09
GS9519130K	13	85	26	12	93,34
GS9519140K	14	85	26	12	123,94
GS9519150K	15	90	26	16	140,84
GS9519160K	16	100	32	16	140,84
GS9519170K	17	100	32	16	167,31
GS9519180K	18	100	32	16	178,34
GS9519190K	19	100	32	20	202,84
GS9519200K	20	105	38	20	208,63
GS9519210K	21	105	38	20	245,81
GS9519220K	22	105	38	20	275,28
GS9519230K	23	120	45	25	308,31
GS9519240K	24	120	45	25	331,66
GS9519250K	25	120	45	25	368,50

# GS-EDL

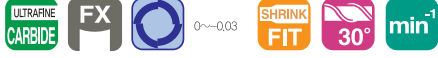
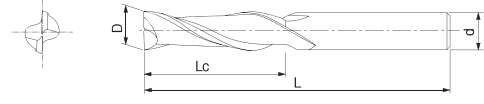

EDP No.	D	L	Lc	d	fiyat \$
GS9522010K	1	60	4	6	20,19
GS9522015K	1,5	60	6	6	20,19
GS9522020K	2	60	9	6	20,19
GS9522030K	3	70	12	6	20,91
GS9522040K	4	70	17	6	21,94
GS9522050K	5	80	20	6	26,56
GS9522060K	6	80	20	6	26,56
GS9522080K	8	90	28	8	38,59
GS9522100K	10	100	34	10	50,47
GS9522120K	12	110	40	12	72,88
GS9522130K	13	120	40	12	126,00
GS9522140K	14	120	40	12	158,44
GS9522150K	15	125	40	16	181,31
GS9522160K	16	135	48	16	183,75
GS9522170K	17	135	48	16	213,31
GS9522180K	18	135	48	16	220,44
GS9522190K	19	135	48	20	232,47
GS9522200K	20	145	56	20	268,44
GS9522210K	21	145	56	20	311,53
GS9522220K	22	145	56	20	338,19
GS9522230K	23	160	67	25	416,22
GS9522240K	24	160	67	25	466,19
GS9522250K	25	160	67	25	527,41

- 2 Ağızlı karbür freze
- Extra uzun boylu helis freze
- 60 HRC'ye kadar sertleştirilmiş çelikler için



# GS-CR-EDS

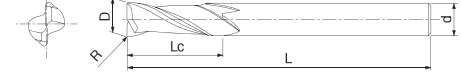

EDP No.	D	L	R	Lc	d	fiyat \$
G2C 010 005	1	50	R0,05	2,5	6	25,69
G2C 010 010	1	50	R0,1	2,5	6	25,69
G2C 010 020	1	50	R0,2	2,5	6	25,69
G2C 010 030	1	50	R0,3	2,5	6	25,69
G2C 015 010	1,5	50	R0,1	4	6	25,69
G2C 015 020	1,5	50	R0,2	4	6	25,69
G2C 015 030	1,5	50	R0,3	4	6	25,69
G2C 015 050	1,5	50	R0,5	4	6	25,69
G2C 020 010	2	50	R0,1	6	6	25,69
G2C 020 020	2	50	R0,2	6	6	25,69
G2C 020 030	2	50	R0,3	6	6	25,69
G2C 020 050	2	50	R0,5	6	6	25,69
G2C 025 010	2,5	60	R0,1	7	6	26,69
G2C 025 020	2,5	60	R0,2	7	6	26,69
G2C 025 030	2,5	60	R0,3	7	6	26,69
G2C 025 050	2,5	60	R0,5	7	6	26,69
G2C 030 010	3	60	R0,1	8	6	26,69
G2C 030 020	3	60	R0,2	8	6	26,69
G2C 030 030	3	60	R0,3	8	6	26,69
G2C 030 050	3	60	R0,5	8	6	26,69
G2C 030 100	3	60	R1	8	6	26,69
G2C 040 010	4	70	R0,1	11	6	27,69
G2C 040 020	4	70	R0,2	11	6	27,69
G2C 040 030	4	70	R0,3	11	6	27,69
G2C 040 050	4	70	R0,5	11	6	27,69
G2C 040 100	4	70	R1	11	6	27,69
G2C 050 010	5	90	R0,1	13	6	30,06
G2C 050 020	5	90	R0,2	13	6	30,06
G2C 050 030	5	90	R0,3	13	6	30,06
G2C 050 050	5	90	R0,5	13	6	30,06
G2C 050 100	5	90	R1	13	6	30,06
G2C 060 010C	6	60	R0,1	15	6	26,69
G2C 060 020C	6	60	R0,2	15	6	26,69
G2C 060 030C	6	60	R0,3	15	6	26,69
G2C 060 050C	6	60	R0,5	15	6	26,69

- 2 Ağızlı karbür freze
- Köşe radyuslu freze
- 60 HRC'ye kadar sertleştirilmiş çelikler için

# GS-CR-EDS

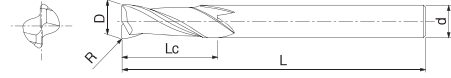

GS-CR-EDS

EDP No.	D	L	R	Lc	d	fiyat \$
G2C 060 100C	6	60	R1	15	6	26,69
G2C 060 150C	6	60	R1,5	15	6	26,69
G2C 060 200C	6	60	R2	15	6	26,69
G2C 060 010	6	90	R0,1	15	6	30,06
G2C 060 020	6	90	R0,2	15	6	30,06
G2C 060 030	6	90	R0,3	15	6	30,06
G2C 060 050	6	90	R0,5	15	6	30,06
G2C 060 100	6	90	R1	15	6	30,06
G2C 060 150	6	90	R1,5	15	6	30,06
G2C 060 200	6	90	R2	15	6	30,06
G2C 080 020C	8	70	R0,2	20	8	42,31
G2C 080 030C	8	70	R0,3	20	8	42,31
G2C 080 050C	8	70	R0,5	20	8	42,31
G2C 080 100C	8	70	R1	20	8	42,31
G2C 080 150C	8	70	R1,5	20	8	42,31
G2C 080 200C	8	70	R2	20	8	42,31
G2C 080 010	8	100	R0,1	20	8	45,47
G2C 080 020	8	100	R0,2	20	8	45,47
G2C 080 030	8	100	R0,3	20	8	45,47
G2C 080 050	8	100	R0,5	20	8	45,47
G2C 080 100	8	100	R1	20	8	45,47
G2C 080 150	8	100	R1,5	20	8	45,47
G2C 080 200	8	100	R2	20	8	45,47
G2C 080 250	8	100	R2,5	20	8	45,47
G2C 080 300	8	100	R3	20	8	45,47
G2C 080 350	8	100	R3,5	20	8	45,47
G2C 080 050B	8	120	R0,5	20	8	57,25
G2C 080 100B	8	120	R1	20	8	57,25
G2C 100 050C	10	75	R0,5	25	10	56,38
G2C 100 100C	10	75	R1	25	10	56,38
G2C 100 010	10	100	R0,1	25	10	62,13
G2C 100 020	10	100	R0,2	25	10	62,13
G2C 100 030	10	100	R0,3	25	10	62,13
G2C 100 050	10	100	R0,5	25	10	62,13
G2C 100 100	10	100	R1	25	10	62,13

# GS-CR-EDS

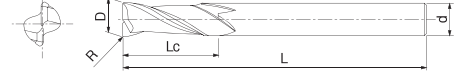

EDP No.	D	L	R	Lc	d	fiyat \$
G2C 100 150	10	100	R1,5	25	10	62,13
G2C 100 200	10	100	R2	25	10	62,13
G2C 100 250	10	100	R2,5	25	10	62,13
G2C 100 300	10	100	R3	25	10	62,13
G2C 100 400	10	100	R4	25	10	62,13
G2C 100 050B	10	130	R0,5	25	10	73,91
G2C 100 100B	10	130	R1	25	10	73,91
G2C 120 050C	12	80	R0,5	30	12	75,19
G2C 120 100C	12	80	R1	30	12	75,19
G2C 120 010	12	110	R0,1	30	12	80,66
G2C 120 020	12	110	R0,2	30	12	80,66
G2C 120 030	12	110	R0,3	30	12	80,66
G2C 120 050	12	110	R0,5	30	12	80,66
G2C 120 100	12	110	R1	30	12	80,66
G2C 120 150	12	110	R1,5	30	12	80,66
G2C 120 200	12	110	R2	30	12	80,66
G2C 120 250	12	110	R2,5	30	12	80,66
G2C 120 300	12	110	R3	30	12	80,66
G2C 120 400	12	110	R4	30	12	80,66
G2C 120 500	12	110	R5	30	12	80,66
G2C 120 050B	12	130	R0,5	30	12	92,44
G2C 120 100B	12	130	R1	30	12	92,44
G2C 160 050	16	150	R0,5	32	16	205,81
G2C 160 100	16	150	R1	32	16	205,81
G2C 160 200	16	150	R2	32	16	205,81

# GS-LN-EDS

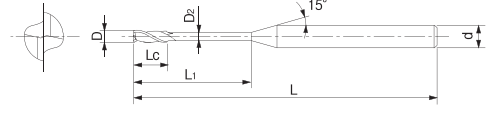

EDP No.	D	L	L <sub>1</sub>	L <sub>c</sub>	d	fiyat \$
GS3120101K	0.1	45	0.3	0.15	4	44,81
GS3120102K	0.1	45	0.5	0.15	4	44,81
GS3120201K	0.2	45	0.5	0.3	4	33,50
GS3120202K	0.2	45	1	0.3	4	33,50
GS3120203K	0.2	45	1.5	0.3	4	33,50
GS3120204K	0.2	45	2	0.3	4	33,50
GS3120302K	0.3	45	1	0.45	4	29,09
GS3120304K	0.3	45	2	0.45	4	29,09
GS3120306K	0.3	45	3	0.45	4	29,09
GS3120307K	0.3	45	4	0.45	4	29,09
GS3120308K	0.3	45	5	0.45	4	29,09
GS3120403K	0.4	45	1	0.6	4	29,09
GS3120404K	0.4	45	2	0.6	4	29,09
GS3120406K	0.4	45	3	0.6	4	29,09
GS3120408K	0.4	45	4	0.6	4	29,09
GS3120409K	0.4	45	5	0.6	4	29,09
GS3120410K	0.4	45	6	0.6	4	29,09
GS3120411K	0.4	45	8	0.6	4	29,09
GS3120412K	0.4	45	10	0.6	4	29,09
GS3120501K	0.5	45	1	0.7	4	25,84
GS3120502K	0.5	45	2	0.7	4	25,84
GS3120503K	0.5	45	3	0.7	4	25,84
GS3120504K	0.5	45	4	0.7	4	25,84
GS3120505K	0.5	45	5	0.7	4	25,84
GS3120506K	0.5	45	6	0.7	4	25,84
GS3120508K	0.5	45	8	0.7	4	25,84
GS3120510K	0.5	45	10	0.7	4	25,84
GS3120512K	0.5	50	12	0.7	4	25,84
GS3120602K	0.6	45	2	0.9	4	25,84
GS3120603K	0.6	45	3	0.9	4	25,84
GS3120604K	0.6	45	4	0.9	4	25,84
GS3120605K	0.6	45	5	0.9	4	25,84
GS3120606K	0.6	45	6	0.9	4	25,84
GS3120608K	0.6	45	8	0.9	4	25,84
GS3120610K	0.6	45	10	0.9	4	25,84

- 2 Ağızlı karbür freze
- Boyunlu geometri
- 60 HRC'ye kadar sertleştirilmiş çelikler için



# GS-LN-EDS

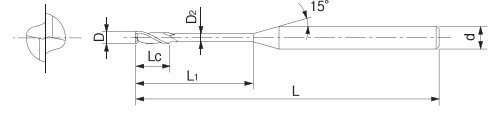

EDP No.	D	L	L <sub>1</sub>	L <sub>c</sub>	d	fiyat \$
GS3120612K	0,6	50	12	0,9	4	25,84
GS3120614K	0,6	50	14	0,9	4	28,44
GS3120702K	0,7	45	2	1	4	24,59
GS3120704K	0,7	45	4	1	4	24,59
GS3120706K	0,7	45	6	1	4	24,59
GS3120708K	0,7	45	8	1	4	24,59
GS3120710K	0,7	45	10	1	4	24,59
GS3120712K	0,7	50	12	1	4	24,59
GS3120804K	0,8	45	4	1,2	4	24,59
GS3120806K	0,8	45	6	1,2	4	24,59
GS3120808K	0,8	45	8	1,2	4	24,59
GS3120810K	0,8	45	10	1,2	4	24,59
GS3120812K	0,8	45	12	1,2	4	25,84
GS3121002K	1	45	2,5	1,5	4	21,31
GS3121004K	1	45	4	1,5	4	21,31
GS3121005K	1	45	5	1,5	4	21,31
GS3121006K	1	45	6	1,5	4	21,31
GS3121008K	1	45	8	1,5	4	21,31
GS3121010K	1	45	10	1,5	4	23,06
GS3121012K	1	45	12	1,5	4	23,06
GS3121014K	1	50	14	1,5	4	23,06
GS3121016K	1	50	16	1,5	4	23,06
GS3121020K	1	55	20	1,5	4	23,06
GS3121206K	1,2	45	6	1,8	4	21,31
GS3121208K	1,2	45	8	1,8	4	21,31
GS3121210K	1,2	45	10	1,8	4	23,06
GS3121212K	1,2	45	12	1,8	4	23,06
GS3121504K	1,5	45	4	2,3	4	21,31
GS3121506K	1,5	45	6	2,3	4	21,31
GS3121508K	1,5	45	8	2,3	4	21,31
GS3121510K	1,5	45	10	2,3	4	21,31
GS3121512K	1,5	45	12	2,3	4	23,06
GS3121514K	1,5	50	14	2,3	4	23,06
GS3121516K	1,5	50	16	2,3	4	23,06
GS3121518K	1,5	55	18	2,3	4	23,06

# GS-LN-EDS

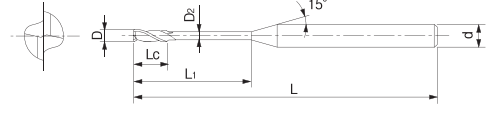
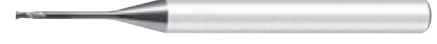

GS-LN-EDS

EDP No.	D	L	L <sub>1</sub>	L <sub>c</sub>	d	fiyat \$
GS3121520K	1,5	55	20	2,3	4	23,06
GS3122006K	2	45	6	3	4	21,31
GS3122008K	2	45	8	3	4	21,31
GS3122010K	2	45	10	3	4	21,31
GS3122012K	2	45	12	3	4	21,31
GS3122014K	2	50	14	3	4	21,31
GS3122016K	2	50	16	3	4	21,31
GS3122018K	2	55	18	3	4	21,31
GS3122020K	2	55	20	3	4	21,31
GS3122025K	2	60	25	3	4	23,06
GS3122030K	2	70	30	3	4	26,34
GS3122508K	2,5	45	8	3,7	4	23,25
GS3122510K	2,5	45	10	3,7	4	23,25
GS3122512K	2,5	45	12	3,7	4	23,25
GS3122514K	2,5	50	14	3,7	4	23,25
GS3122516K	2,5	50	16	3,7	4	23,25
GS3122520K	2,5	55	20	3,7	4	25,56
GS3122525K	2,5	60	25	3,7	4	25,56
GS3122530K	2,5	70	30	3,7	4	28,13
GS3123008K	3	45	8	4,5	6	23,69
GS3123010K	3	45	10	4,5	6	23,69
GS3123012K	3	45	12	4,5	6	23,69
GS3123014K	3	50	14	4,5	6	23,69
GS3123016K	3	55	16	4,5	6	23,69
GS3123018K	3	55	18	4,5	6	26,19
GS3123020K	3	60	20	4,5	6	26,19
GS3123025K	3	65	25	4,5	6	26,19
GS3123030K	3	80	30	4,5	6	32,09
GS3123035K	3	90	35	4,5	6	32,25
GS3123040K	3	90	40	4,5	6	32,25
GS3124010K	4	45	10	6	6	25,06
GS3124012K	4	50	12	6	6	25,06
GS3124016K	4	60	16	6	6	25,06
GS3124020K	4	60	20	6	6	27,47
GS3124025K	4	70	25	6	6	27,47
GS3124030K	4	80	30	6	6	32,09
GS3124035K	4	90	35	6	6	32,25
GS3124040K	4	90	40	6	6	32,25
GS3124045K	4	100	45	6	6	35,34
GS3124050K	4	100	50	6	6	36,47

# GS-LN-CR-EDS

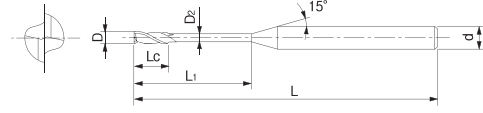

EDP No.	D	L	L <sub>1</sub>	R	L <sub>c</sub>	d	fiyat \$
GS8560801K	0,8	45	4	R0,1	1,2	4	28,22
GS8560802K	0,8	45	4	R0,2	1,2	4	29,63
GS8560811K	0,8	45	6	R0,1	1,2	4	28,22
GS8560813K	0,8	45	6	R0,2	1,2	4	29,63
GS8560814K	0,8	45	8	R0,1	1,2	4	29,63
GS8561033K	1	45	4	R0,1	1,5	4	24,34
GS8561034K	1	45	4	R0,2	1,5	4	24,34
GS8561035K	1	45	4	R0,3	1,5	4	24,34
GS8561036K	1	45	6	R0,1	1,5	4	24,34
GS8561037K	1	45	6	R0,2	1,5	4	24,34
GS8561004K	1	45	6	R0,3	1,5	4	24,34
GS8561014K	1	45	8	R0,1	1,5	4	24,34
GS8561024K	1	45	8	R0,3	1,5	4	24,34
GS8561026K	1	45	10	R0,1	1,5	4	24,34
GS8561005K	1	45	10	R0,2	1,5	4	24,34
GS8561029K	1	45	10	R0,3	1,5	4	24,34
GS8561030K	1	45	12	R0,1	1,5	4	24,34
GS8561006K	1	45	12	R0,2	1,5	4	24,34
GS8561032K	1	45	12	R0,3	1,5	4	24,34
GS8561204K	1,2	45	4	R0,1	1,8	4	25,63
GS8561205K	1,2	45	4	R0,2	1,8	4	25,63
GS8561206K	1,2	45	4	R0,3	1,8	4	25,63
GS8561207K	1,2	45	6	R0,1	1,8	4	25,63
GS8561208K	1,2	45	6	R0,2	1,8	4	25,63
GS8561209K	1,2	45	6	R0,3	1,8	4	25,63
GS8561210K	1,2	45	8	R0,1	1,8	4	25,63
GS8561211K	1,2	45	8	R0,2	1,8	4	25,63
GS8561212K	1,2	45	8	R0,3	1,8	4	25,63
GS8561213K	1,2	45	10	R0,1	1,8	4	25,63
GS8561214K	1,2	45	10	R0,2	1,8	4	25,63
GS8561215K	1,2	45	10	R0,3	1,8	4	25,63
GS8561216K	1,2	45	12	R0,1	1,8	4	25,63
GS8561217K	1,2	45	12	R0,2	1,8	4	25,63
GS8561218K	1,2	45	12	R0,3	1,8	4	25,63
GS8561501K	1,5	45	4	R0,1	2,3	4	25,63

- 2 Ağızlı karbür freze
- Boyunlu geometri
- Köşe radyuslu freze
- 60 HRC'ye kadar sertleştirilmiş çelikler için

# GS-LN-CR-EDS

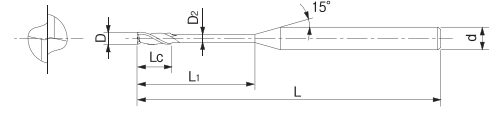

EDP No.	D	L	L <sub>1</sub>	R	L <sub>c</sub>	d	fiyat \$
GS8561510K	1,5	45	4	R0,5	2,3	4	24,91
GS8561511K	1,5	45	6	R0,1	2,3	4	24,91
GS8561515K	1,5	45	6	R0,2	2,3	4	24,91
GS8561516K	1,5	45	6	R0,3	2,3	4	24,91
GS8561517K	1,5	45	6	R0,5	2,3	4	24,91
GS8561518K	1,5	45	8	R0,1	2,3	4	24,91
GS8561519K	1,5	45	8	R0,2	2,3	4	24,91
GS8561520K	1,5	45	8	R0,3	2,3	4	24,91
GS8561521K	1,5	45	8	R0,5	2,3	4	24,91
GS8561526K	1,5	45	10	R0,1	2,3	4	24,91
GS8561527K	1,5	45	10	R0,3	2,3	4	24,91
GS8561528K	1,5	45	10	R0,5	2,3	4	24,91
GS8561529K	1,5	45	12	R0,1	2,3	4	24,91
GS8561530K	1,5	45	12	R0,3	2,3	4	24,91
GS8561531K	1,5	45	12	R0,5	2,3	4	24,91
GS8561532K	1,5	50	16	R0,2	2,3	4	24,91
GS8561533K	1,5	50	16	R0,3	2,3	4	24,91
GS8561534K	1,5	55	20	R0,3	2,3	4	26,22
GS8562044K	2	45	6	R0,2	3	4	24,34
GS8562045K	2	45	6	R0,3	3	4	24,34
GS8562046K	2	45	6	R0,5	3	4	24,34
GS8562001K	2	45	8	R0,1	3	4	25,47
GS8562027K	2	45	8	R0,2	3	4	24,34
GS8562028K	2	45	8	R0,3	3	4	24,34
GS8562049K	2	45	8	R0,5	3	4	24,34
GS8562051K	2	45	9	R0,5	3	4	24,34
GS8562029K	2	45	10	R0,1	3	4	25,63
GS8562030K	2	45	10	R0,2	3	4	25,63
GS8562031K	2	45	10	R0,3	3	4	25,63
GS8562032K	2	45	12	R0,2	3	4	25,63
GS8562033K	2	45	12	R0,3	3	4	25,63
GS8562034K	2	50	16	R0,2	3	4	25,63
GS8562035K	2	50	16	R0,3	3	4	25,63
GS8562040K	2	50	16	R0,5	3	4	24,91
GS8562036K	2	55	20	R0,2	3	4	26,94



# GS-LN-CR-EDS

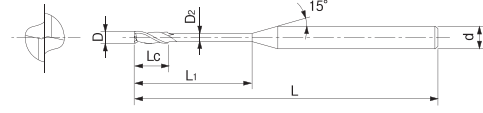

EDP No.	D	L	L <sub>1</sub>	R	L <sub>c</sub>	d	fiyat \$
GS8562037K	2	55	20	R0,3	3	4	26,94
GS8562039K	2	55	20	R0,5	3	4	26,94
GS8562042K	2	60	25	R0,3	3	4	28,94
GS8562043K	2	60	25	R0,5	3	4	28,94
GS8562502K	2,5	45	10	R0,2	3,7	4	24,91
GS8562503K	2,5	45	10	R0,3	3,7	4	24,91
GS8562504K	2,5	45	10	R0,5	3,7	4	24,91
GS8562505K	2,5	45	12	R0,2	3,7	4	24,91
GS8562506K	2,5	45	12	R0,3	3,7	4	24,91
GS8562507K	2,5	45	12	R0,5	3,7	4	24,91
GS8562508K	2,5	50	16	R0,2	3,7	4	24,91
GS8562509K	2,5	50	16	R0,3	3,7	4	24,91
GS8562510K	2,5	50	16	R0,5	3,7	4	24,91
GS8562511K	2,5	55	20	R0,2	3,7	4	24,91
GS8562512K	2,5	55	20	R0,3	3,7	4	24,91
GS8562513K	2,5	55	20	R0,5	3,7	4	24,91
GS8563001K	3	55	8	R0,2	4	6	25,47
GS8563002K	3	55	8	R0,3	4	6	25,47
GS8563004K	3	55	8	R0,5	4	6	25,47
GS8563003K	3	55	9	R0,3	4	6	25,47
GS8563005K	3	55	9	R0,5	4	6	25,47
GS8563011K	3	45	10	R0,2	4,5	6	25,47
GS8563006K	3	55	10	R0,3	4	6	26,03
GS8563007K	3	55	10	R0,5	4	6	26,03
GS8563008K	3	55	12	R0,3	4	6	26,03
GS8563009K	3	55	12	R0,5	4	6	26,03
GS8563012K	3	55	16	R0,2	4,5	6	26,03
GS8563010K	3	55	16	R0,3	4	6	26,03
GS8563015K	3	55	16	R0,5	4	6	26,03
GS8563013K	3	60	20	R0,2	4,5	6	29,19
GS8563016K	3	55	20	R0,3	4	6	27,78
GS8563025K	3	55	20	R0,5	4	6	27,78
GS8563014K	3	65	25	R0,5	4,5	6	32,13
GS8564001K	4	55	10	R0,2	5	6	26,59
GS8564002K	4	55	12	R0,2	5	6	26,59

# GS-LN-CR-EDS

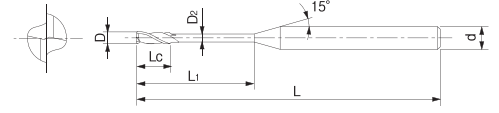

EDP No.	D	L	L <sub>1</sub>	R	L <sub>c</sub>	d	fiyat \$
GS8564003K	4	55	12	R0,3	5	6	26,59
GS8564005K	4	55	12	R0,5	5	6	26,59
GS8564006K	4	55	12	R1,0	5	6	26,59
GS8564007K	4	55	16	R0,2	5	6	26,59
GS8564008K	4	55	16	R0,3	5	6	26,59
GS8564015K	4	55	16	R0,5	5	6	26,59
GS8564016K	4	55	16	R1,0	5	6	26,59
GS8564017K	4	55	20	R0,3	5	6	28,56
GS8564025K	4	55	20	R0,5	5	6	28,56
GS8564026K	4	55	20	R1,0	5	6	28,56
GS8564027K	4	55	25	R0,3	5	6	30,00
GS8564028K	4	70	25	R0,5	6	6	33,00
GS8566001K	6	60	15	R0,2	7	6	29,56
GS8566002K	6	60	15	R0,3	7	6	29,56
GS8566004K	6	60	15	R0,5	7	6	29,56
GS8566006K	6	60	15	R1,0	7	6	29,56
GS8566003K	6	60	20	R0,3	7	6	31,13
GS8566005K	6	60	20	R0,5	7	6	31,13
GS8566010K	6	60	20	R1,0	7	6	28,41
GS8566015K	6	60	20	R1,5	7	6	28,53
GS8568001K	8	60	15	R0,5	9	8	34,88
GS8568002K	8	60	20	R1,0	9	8	34,88
GS8568003K	8	60	25	R0,3	9	8	34,88
GS8568004K	8	60	25	R0,5	9	8	34,88
GS8568010K	8	60	25	R1,0	9	8	34,88
GS8568015K	8	60	25	R1,5	9	8	34,88
GS8570002K	10	70	25	R1,0	11	10	47,66
GS8570003K	10	70	32	R0,3	11	10	50,16
GS8570004K	10	70	32	R0,5	11	10	50,16
GS8570010K	10	70	32	R1,0	11	10	50,16
GS8570015K	10	70	32	R1,5	11	10	50,16
GS8572002K	12	80	30	R0,5	12	12	60,97
GS8572003K	12	80	30	R1,0	12	12	60,97
GS8572004K	12	80	38	R0,5	12	12	60,97
GS8572010K	12	80	38	R1,0	12	12	60,97
GS8572015K	12	80	38	R1,5	12	12	60,97

# GS-EMS

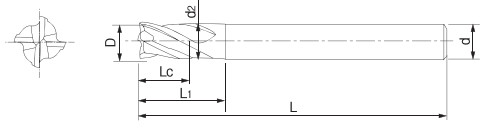

EDP No.	D	L	Lc	d	fiyat \$
GS9520010K	1	40	2,5	6	21,25
GS9520015K	1,5	40	4	6	21,25
GS9520020K	2	40	6	6	21,25
GS9520025K	2,5	40	8	6	21,25
GS9520030K	3	45	8	6	21,25
GS9520035K	3,5	45	10	6	21,25
GS9520040K	4	45	11	6	21,25
GS9520045K	4,5	45	11	6	21,25
GS9520050K	5	50	13	6	22,59
GS9520055K	5,5	50	13	6	22,59
GS9520060K	6	50	13	6	22,59
GS9620060K	6	60	15	6	22,59
GS9520065K	6,5	60	16	8	34,97
GS9520070K	7	60	16	8	34,97
GS9520075K	7,5	60	16	8	34,97
GS9520080K	8	60	19	8	36,56
GS9620080K	8	70	20	8	36,56
GS9520085K	8,5	70	19	10	47,13
GS9520090K	9	70	19	10	47,13
GS9520095K	9,5	70	19	10	47,13
GS9520100K	10	70	22	10	48,09
GS9620100K	10	75	25	10	48,09
GS9520105K	10,5	75	22	12	59,75
GS9520110K	11	75	22	12	59,75
GS9520120K	12	75	26	12	59,97
GS9620120K	12	80	30	12	59,97
GS9520130K	13	85	26	12	101,72
GS9520140K	14	85	26	12	137,59
GS9520150K	15	90	26	16	149,31
GS9520160K	16	100	32	16	160,59
GS9520170K	17	100	32	16	175,66
GS9520180K	18	100	32	16	190,75
GS9520190K	19	100	32	20	214,75
GS9520200K	20	105	38	20	229,53
GS9520210K	21	105	38	20	258,09
GS9520220K	22	105	38	20	289,06
GS9520230K	23	120	45	25	323,75
GS9520240K	24	120	45	25	354,66
GS9520250K	25	120	45	25	388,44

- Çok ağızlı parmak freze
- 60 HRC'ye kadar sertleştirilmiş çelikler için

# GS-EML

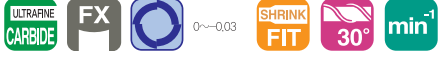
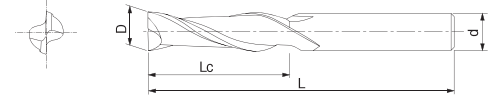

EDP No.	D	L	Lc	d	fiyat \$
GS9523020K	2	60	9	6	23,94
GS9523030K	3	70	12	6	23,06
GS9523040K	4	70	17	6	24,31
GS9523050K	5	80	20	6	30,13
GS9523060K	6	80	20	6	29,25
GS9523080K	8	90	28	8	39,34
GS9523100K	10	100	34	10	54,63
GS9523120K	12	110	40	12	74,13
GS9523130K	13	120	40	12	137,34
GS9523140K	14	120	40	12	174,38
GS9523150K	15	125	40	16	194,78
GS9523160K	16	135	48	16	215,19
GS9523170K	17	135	48	16	255,78
GS9523180K	18	135	48	16	279,31
GS9523190K	19	135	48	20	286,09
GS9523200K	20	145	56	20	314,66
GS9523220K	22	145	56	20	372,03
GS9523230K	23	160	67	25	420,88
GS9523240K	24	160	67	25	479,88
GS9523250K	25	160	67	25	556,53

- Extra uzun boylu helis freze
- 60 HRC'ye kadar sertleştirilmiş çelikler için

# GS-CR-EMS

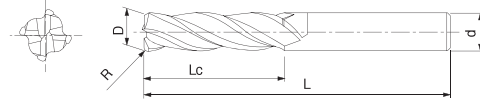

EDP No.	D	L	R	Lc	d	fiyat \$
G4C 010 005	1	50	R0,05	2,5	6	28,31
G4C 010 010	1	50	R0,1	2,5	6	28,31
G4C 010 020	1	50	R0,2	2,5	6	28,31
G4C 010 030	1	50	R0,3	2,5	6	28,31
G4C 015 005	1,5	50	R0,05	4	6	28,31
G4C 015 010	1,5	50	R0,1	4	6	28,31
G4C 015 020	1,5	50	R0,2	4	6	28,31
G4C 015 030	1,5	50	R0,3	4	6	28,31
G4C 015 050	1,5	50	R0,5	4	6	28,31
G4C 020 010	2	50	R0,1	6	6	28,31
G4C 020 020	2	50	R0,2	6	6	28,31
G4C 020 030	2	50	R0,3	6	6	28,31
G4C 020 050	2	50	R0,5	6	6	28,31
G4C 025 010	2,5	60	R0,1	7	6	29,31
G4C 025 020	2,5	60	R0,2	7	6	29,31
G4C 025 030	2,5	60	R0,3	7	6	29,31
G4C 025 050	2,5	60	R0,5	7	6	29,31
G4C 030 010	3	60	R0,1	8	6	29,31
G4C 030 020	3	60	R0,2	8	6	29,31
G4C 030 030	3	60	R0,3	8	6	29,31
G4C 030 050	3	60	R0,5	8	6	29,31
G4C 030 100	3	60	R1	8	6	29,31
G4C 040 010	4	70	R0,1	11	6	30,44
G4C 040 020	4	70	R0,2	11	6	30,44
G4C 040 030	4	70	R0,3	11	6	30,44
G4C 040 050	4	70	R0,5	11	6	30,44
G4C 040 100	4	70	R1	11	6	30,44
G4C 050 010	5	90	R0,1	13	6	33,06
G4C 050 020	5	90	R0,2	13	6	33,06
G4C 050 030	5	90	R0,3	13	6	33,06
G4C 050 050	5	90	R0,5	13	6	33,06
G4C 050 100	5	90	R1	13	6	33,06
G4C 060 010C	6	60	R0,1	15	6	29,31
G4C 060 020C	6	60	R0,2	15	6	29,31
G4C 060 010	6	90	R0,1	15	6	33,06

- Çok ağızlı parmak freze
- Köşe radyuslu freze
- 60 HRC'ye kadar sertleştirilmiş çelikler için

# GS-CR-EMS

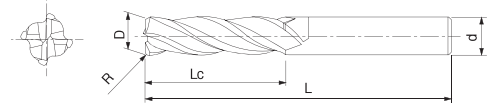

EDP No.	D	L	R	Lc	d	fiyat \$
G4C 060 020	6	90	R0.2	15	6	33,06
G4C 060 030	6	90	R0.3	15	6	33,06
G4C 060 050	6	90	R0.5	15	6	33,06
G4C 060 100	6	90	R1	15	6	33,06
G4C 060 150	6	90	R1.5	15	6	33,06
G4C 060 200	6	90	R2	15	6	33,06
G4C 060 050B	6	110	R0.5	15	6	39,47
G4C 060 100B	6	110	R1	15	6	39,47
G4C 080 030C	8	70	R0.3	20	8	47,09
G4C 080 050C	8	70	R0.5	20	8	47,09
G4C 080 100C	8	70	R1	20	8	47,09
G4C 080 010	8	100	R0.1	20	8	53,09
G4C 080 020	8	100	R0.2	20	8	53,09
G4C 080 030	8	100	R0.3	20	8	53,09
G4C 080 050	8	100	R0.5	20	8	53,09
G4C 080 100	8	100	R1	20	8	53,09
G4C 080 150	8	100	R1.5	20	8	53,09
G4C 080 200	8	100	R2	20	8	53,09
G4C 080 250	8	100	R2.5	20	8	53,09
G4C 080 300	8	100	R3	20	8	53,09
G4C 080 050B	8	120	R0.5	20	8	63,00
G4C 080 100B	8	120	R1	20	8	63,00
G4C 100 030C	10	75	R0.3	25	10	62,00
G4C 100 050C	10	75	R0.5	25	10	62,00
G4C 100 100C	10	75	R1	25	10	62,00
G4C 100 010	10	100	R0.1	25	10	68,38
G4C 100 020	10	100	R0.2	25	10	68,38
G4C 100 030	10	100	R0.3	25	10	68,38
G4C 100 050	10	100	R0.5	25	10	68,38
G4C 100 100	10	100	R1	25	10	68,38
G4C 100 150	10	100	R1.5	25	10	68,38
G4C 100 200	10	100	R2	25	10	68,38
G4C 100 250	10	100	R2.5	25	10	68,38
G4C 100 300	10	100	R3	25	10	68,38
G4C 100 050B	10	130	R0.5	22	10	81,28

# GS-CR-EMS

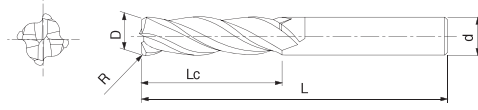

EDP No.	D	L	R	Lc	d	fiyat \$
G4C 100 100B	10	130	R1	22	10	81,28
G4C 120 030C	12	80	R0,3	30	12	83,81
G4C 120 050C	12	80	R0,5	30	12	83,81
G4C 120 100C	12	80	R1	30	12	83,81
G4C 120 010	12	110	R0,1	30	12	94,06
G4C 120 020	12	110	R0,2	30	12	94,06
G4C 120 030	12	110	R0,3	30	12	94,06
G4C 120 050	12	110	R0,5	30	12	94,06
G4C 120 100	12	110	R1	30	12	94,06
G4C 120 150	12	110	R1,5	30	12	94,06
G4C 120 200	12	110	R2	30	12	94,06
G4C 120 250	12	110	R2,5	30	12	94,06
G4C 120 300	12	110	R3	30	12	94,06
G4C 120 350	12	110	R3,5	30	12	94,06
G4C 120 400	12	110	R4	30	12	94,06
G4C 120 500	12	110	R5	30	12	94,06
G4C 120 050B	12	130	R0,5	30	12	101,72
G4C 120 100B	12	130	R1	30	12	101,72
G4C 160 050	16	150	R0,5	32	16	226,34
G4C 160 100	16	150	R1	32	16	226,34
G4C 160 200	16	150	R2	32	16	226,34



# GS-RESF

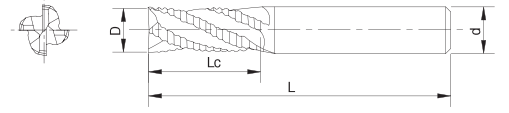

EDP No.	D	L	Lc	d	fiyat \$
GS3016906K	6	50	13	6	30,94
GS3016908K	8	60	19	8	46,22
GS3016910K	10	70	22	10	63,13
GS3016912K	12	75	26	12	81,06
GS3016914K	14	85	26	12	149,44
GS3016916K	16	100	32	16	213,19
GS3016920K	20	105	38	20	301,25

- Çok ağızlı karbür freze
- Kaba talaş operasyonları için, talaş kırıcılı
- 60 HRC'ye kadar sertleştirilmiş çelikler için

# AL SERİLERİ

- Alüminyum için karbür frezeler

AL+MG-ED

AL+MG-ET

AL+MG-REE

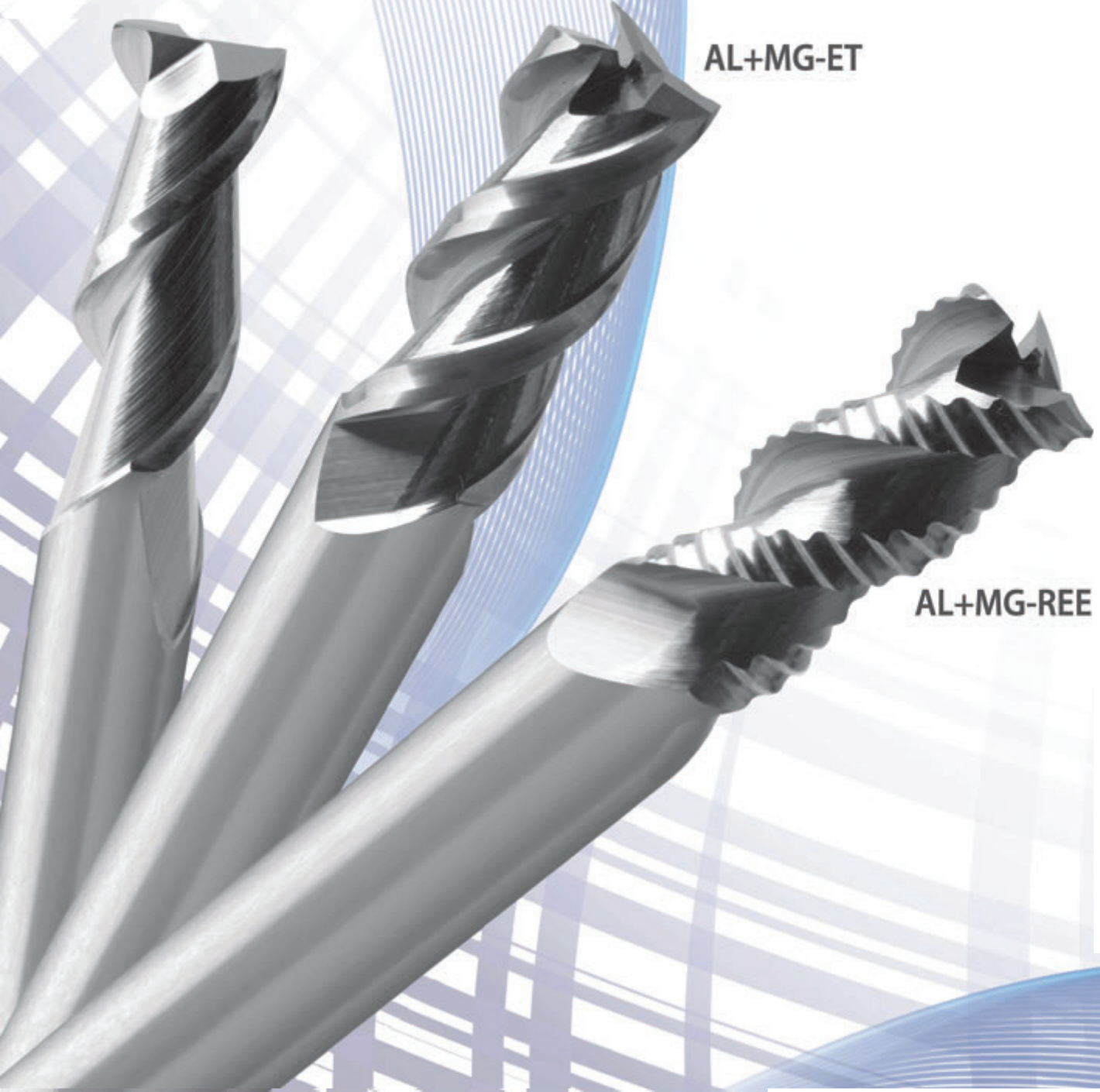

# AL+MG-ET

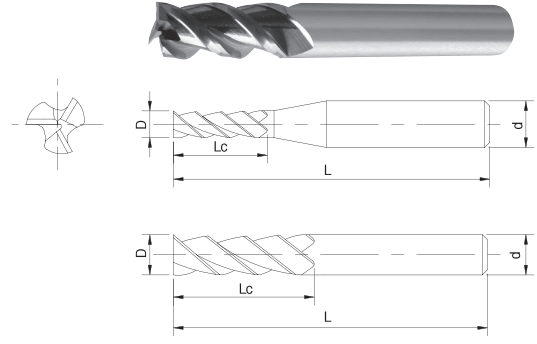

EDP No.	D	L	Lc	d	fiyat \$
A3F 010 02	1	40	2	6	18,53
A3F 010 025		40	2,5	6	18,53
A3F 010		50	3	6	19,53
A3F 010 04		60	4	6	21,53
A3F 010 06		60	6	6	21,53
A3F 012		1,2	50	4	6
A3F 015 03	1,5	40	3	6	18,53
A3F 015		50	5	6	19,53
A3F 015 06		60	6	6	21,53
A3F 015 08		60	8	6	21,53
A3F 015 10		60	10	6	23,66
A3F 020 03	2	40	3	6	18,53
A3F 020		50	6	6	19,53
A3F 020 08		60	8	6	21,53
A3F 020 10		60	10	6	21,53
A3F 020 12		60	12	6	21,53
A3F 025 08		2,5	40	8	6
A3F 025	55		10	6	21,53
A3F 025 12	60		12	6	21,53
A3F 030 04	3	45	4	6	19,53
A3F 030 08		45	8	6	19,53
A3F 030		55	11	6	21,53
A3F 030 15		65	15	6	23,66
A3F 030 20		70	20	6	24,81
A3F 030 25		75	25	6	26,06
A3F 030 30		80	30	6	27,44
A3F 035	3,5	55	12	6	21,53
A3F 040 05	4	45	5	6	19,53
A3F 040 08		45	8	6	19,53
A3F 040 11		45	11	6	19,53
A3F 040		55	13	6	21,53
A3F 040 16		65	16	6	23,66
A3F 040 20		70	20	6	24,81
A3F 040 26		75	26	6	26,06
A3F 040 30		80	30	6	27,44

- 3 ağızlı karbür freze
- Alüminyum malzemeler için
- Kaplamasız

# AL+MG-ET

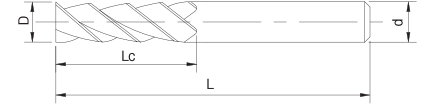
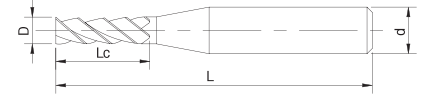

0~0.015



EDP No.	D	L	Lc	d	fiyat \$
A3F 045	4,5	55	15	6	21,53
A3F 050 06	5	45	6	6	19,53
A3F 050		55	17	6	21,53
A3F 050 22		60	22	6	21,53
A3F 050 26		70	26	6	22,66
A3F 050 31		75	31	6	23,66
A3F 050 36		80	36	6	24,94
A3F 050 41		85	41	6	26,06
A3F 050 46		90	46	6	27,44
A3F 055		5,5	55	17	6
A3F 060 07	6	50	7	6	20,28
A3F 060 13		50	13	6	20,28
A3F 060		60	17	6	21,53
A3F 060 22		60	22	6	21,53
A3F 060 26		70	26	6	22,66
A3F 060 31		75	31	6	23,66
A3F 060 36		80	36	6	24,94
A3F 060 43		90	43	6	27,44
A3F 060 51		100	51	6	30,06
A3F 070	7	65	23	8	30,56
A3F 080 10	8	60	10	8	29,06
A3F 080 20		60	20	8	29,06
A3F 080		70	23	8	30,56
A3F 080 29		80	29	8	33,56
A3F 080 31		80	31	8	33,56
A3F 080 36		85	36	8	35,19
A3F 080 41		90	41	8	36,94
A3F 080 46		95	46	8	38,81
A3F 080 51		100	51	8	40,72
A3F 080 56	105	56	8	42,84	
A3F 080 66	110	66	8	44,97	
A3F 090	9	70	28	10	42,47
A3F 100 12	10	65	12	10	40,34
A3F 100 23		65	23	10	40,34
A3F 100		75	28	10	42,47

# AL+MG-ET

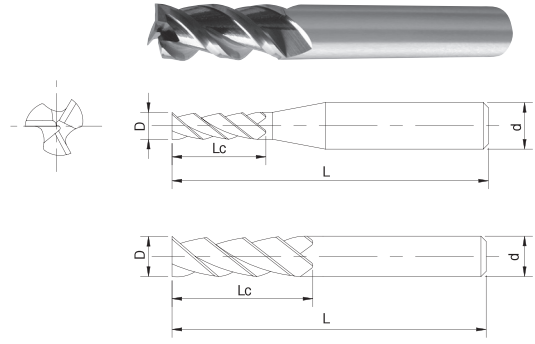

EDP No.	D	L	Lc	d	fiyat \$
A3F 100 33	10	90	33	10	48,72
A3F 100 36		90	36	10	48,72
A3F 100 41		90	41	10	48,72
A3F 100 46		100	46	10	53,63
A3F 100 51		100	51	10	53,63
A3F 100 56		110	56	10	59,00
A3F 100 61		110	61	10	59,00
A3F 100 66		120	66	10	64,88
A3F 120 14		12	70	14	12
A3F 120 27	70		27	12	53,88
A3F 120	80		33	12	56,75
A3F 120 41	95		41	12	65,13
A3F 120 46	100		46	12	68,38
A3F 120 51	100		51	12	68,38
A3F 120 56	110		56	12	75,28
A3F 120 61	110		61	12	75,28
A3F 120 66	120		66	12	82,81
A3F 120 71	120		71	12	82,81
A3F 120 76	135	76	12	95,31	
A3F 140	14	90	38	16	131,16
A3F 160 19		90	19	16	131,16
A3F 160 33		90	33	16	131,16
A3F 160		100	43	16	138,16
A3F 160 53		105	53	16	141,53
A3F 160 56		110	56	16	145,06
A3F 160 66		130	66	16	159,56
A3F 160 76		150	76	16	175,38
A3F 160 86		160	86	16	184,13
A3F 160 96		180	96	16	202,69
A3F 160 106	190	106	16	212,81	
A3F 160 116	200	116	16	223,47	
A3F 180	18	100	49	16	201,53
A3F 200 23		90	23	20	204,41
A3F 200 39		90	39	20	204,41
A3F 200	20	100	49	20	215,19
A3F 200 56		110	56	20	225,84
A3F 200 66		130	66	20	248,53
A3F 200 76		150	76	20	273,31
A3F 200 86		160	86	20	286,97
A3F 200 96		180	96	20	315,66
A3F 200 106		190	106	20	331,56
A3F 200 116		200	116	20	348,09
A3F 200 126		220	126	20	382,91

# AL+MG-ED

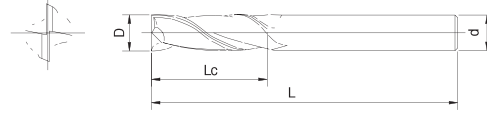

EDP No.	D	L	Lc	d	fiyat \$
A2F 010	1	50	3	6	17,78
A2F 010 06		60	6	6	19,53
A2F 012	1,2	50	4	6	17,78
A2F 015	1,5	50	5	6	17,78
A2F 015 08		60	8	6	19,53
A2F 020	2	50	6	6	17,78
A2F 020 10		60	10	6	19,53
A2F 025	2,5	55	10	6	19,53
A2F 030	3	55	11	6	19,53
A2F 030 15		65	15	6	21,53
A2F 040	4	55	13	6	19,53
A2F 040 16		65	16	6	21,53
A2F 050	5	55	17	6	19,53
A2F 050 22		60	22	6	19,53
A2F 060	6	60	17	6	19,53
A2F 060 26		70	26	6	20,66
A2F 070	7	65	23	8	27,81
A2F 080	8	70	23	8	27,81
A2F 080 31		80	31	8	30,56
A2F 100	10	75	28	10	38,59
A2F 100 36		90	36	10	44,34
A2F 120	12	80	33	12	51,63
A2F 120 41		95	41	12	59,25
A2F 140	14	90	38	14	88,31
A2F 140 S16		90	38	16	119,25
A2F 160	16	100	43	16	125,63
A2F 160 53		105	53	16	131,91
A2F 180	18	100	49	16	183,25
A2F 200	20	100	49	20	195,66
A2F 200 56		110	56	20	205,28

- 2 ağızlı karbür freze
- Alüminyum malzemeler için
- Kaplamasız

# AL+MG-REE

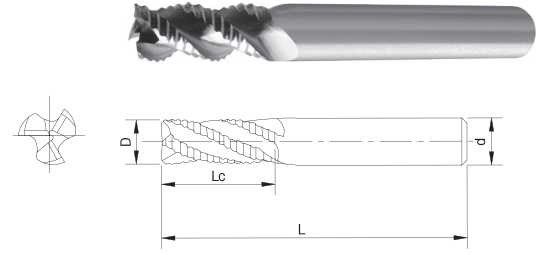

EDP No.	D	L	Lc	d	fiyat \$
A3R 060	6	60	15	6	29,31
A3R 060 25		80	25	6	34,06
A3R 080	8	65	20	8	36,19
A3R 080 30		90	30	8	43,59
A3R 100	10	70	25	10	50,09
A3R 100 40		100	40	10	63,38
A3R 120	12	80	30	12	67,13
A3R 120 50		110	50	12	88,94
A3R 140	14	90	35	16	155,06
A3R 160	16	100	42	16	163,34
A3R 160 52		150	52	16	207,44
A3R 180	18	100	45	20	238,25
A3R 200	20	100	48	20	254,41
A3R 200 55		160	55	20	339,19

- 3 ağızlı karbür freze
- Kaba talaş operasyonları için, talaş kırıcılı
- Alüminyum için karbür freze
- Kaplamasız



# CRN SERİLERİ

- CRN kaplamalı Alüminyum malzeme işleme frezeleri



# CRN-LN-EDS

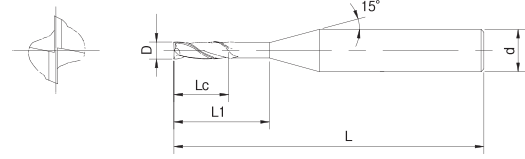

EDP No.	D	L	L <sub>1</sub>	L <sub>c</sub>	d	fiyat \$
8530504K	0.5	45	4	0.7	4	28,13
8530506K			6			28,13
8530508K			8			28,13
8531004K	1	45	4	1.5	6	25,28
8531006K			6			25,28
8531008K			8			25,28
8531010K			10			25,28
8531575K	1.5	45	7.5	2.3	6	23,19
8531515K		50	15			23,19
8532010K	2	45	10	3	6	23,19
8532012K			12			23,19
8532014K		50	14			23,19
8532016K			16			23,19
8532018K		55	18			23,19
8532020K			20			23,19
8532513K	2.5	45	12.5	3.7	6	23,19
8532518K		55	17.5			23,19
8532525K		70	25			25,28
8533015K	3	55	15	4.5	6	23,19
8533030K		70	30			31,09
8534020K	4	60	20	6	6	26,66
8534040K		80	40			31,09

- 2 ağızlı karbür freze
- Boyunlu geometri
- Alüminyum malzeme işlemek için
- CRN Kaplamalı

# CRN-LN-CR-EDS

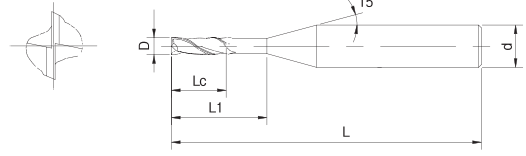

EDP No.	D	L	L1	R	Lc	d	fiyat \$
8512005K	2	55	8	R0,5	3	6	20,97
8512015K			12				20,97
8513005K	3	55	8	R0,5	5	6	24,34
8513015K			16				24,34
8513025K			20				26,56
8514005K	4	55	12	R0,5	5	6	25,41
8514015K			16				25,41
8514025K			20				27,97
8516005K	6	60	60	R0,5	7	6	32,63
8516010K			60	R1,0			27,69
8516015K			60	R1,5			27,69
8518010K	8	60	60	R1	9	6	34,16
8518015K			60	R1,5		8	34,16
8520010K	10	70	70	R1	11	8	49,38
8520015K			70	R1,5		10	49,38
8522005K	12	80	80	R0,5	12	10	60,25
8522010K			80	R1		12	60,25
8522015K			80	R1,5		12	60,25

- 2 ağızlı karbür freze
- Boyunlu geometri
- Alüminyum malzeme işlemek için
- Köşe radyuslu karbür freze
- CRN Kaplamalı

# CRN-EBD

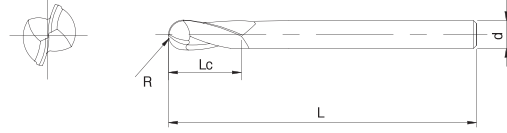

EDP No.	R	L	Lc	d	fiyat \$
8503705K	R0,25	60	1	4	48,56
8503706K	R0,3	60	1,1	4	48,56
8503708K	R0,4	60	2	4	48,56
8503710K	R0,5	60	2,5	4	40,47
8503712K	R0,6	60	3	4	40,47
8503714K	R0,7	60	3,5	4	40,47
8503715K	R0,75	60	4	4	40,47
8503716K	R0,8	60	4	4	40,47
8503718K	R0,9	60	4,5	4	40,47
8503720K	R1	60	5	6	40,47
8503725K	R1,25	70	6	6	40,47
8503730K	R1,5	70	8	6	40,47
8503735K	R1,75	70	8	6	40,47
8503740K	R2	80	8	6	40,47
8503741K	R2	70	8	4	40,47
8503750K	R2,5	90	10	6	45,16
8503860K	R3	90	12	6	45,16
8503880K	R4	110	14	8	52,84
8503900K	R5	125	18	10	77,34
8503920K	R6	140	22	12	100,25

- Küresel karbür freze
- Alüminyum malzeme işlemek için
- CRN kaplamalı

# CRN-LN-EBD

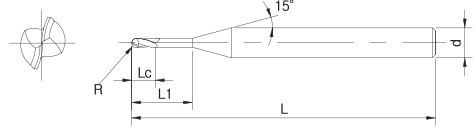

EDP No.	R	L	L <sub>1</sub>	L <sub>c</sub>	d	fiyat \$			
8500504K	R0,25	45	4	0,7	4	39,31			
8500506K			6			40,47			
8500508K			8			40,47			
8501004K	R0,5	45	4	1,5	6	30,59			
8501006K			6			30,59			
8501008K			8			30,59			
8501001K			10			31,88			
8501206K	R0,6	45	6	1,8	6	31,88			
8501608K	R0,8	45	8	2,4	6	31,88			
8502006K	R1	45	6	3	6	29,31			
8502008K			8			29,31			
8502001K			10			30,59			
8502012K			12			30,59			
8502014K		50	14			30,59			
8502016K			16			30,59			
8502018K			18			30,59			
8502002K		55	20			32,91			
8503012K		R1,5	45			12	4,5	6	33,16
8503014K			50			14			34,97
8503016K	55		16	34,97					
8503018K			18	34,97					
8503020K	60		20	34,97					
8503025K	65		25	37,00					
8503030K	70		30	38,16					
8503035K	80		35	38,16					
8504012K	R2	60	12	6	6	33,16			
8504016K			16			34,97			
8504020K			20			34,97			
8504025K			25			37,00			
8504030K		80	30			38,16			
8504035K			35			42,38			
8504040K			40			47,34			
8504045K		90	45			61,06			
8504050K		100	50			66,03			

- Küresel karbür freze
- Boyunlu geometri
- Alüminyum malzemeler için
- CRN kaplamalı

# WS SERİLERİ

- WS Serisi karbür frezeler
- 70 HRC'ye kadar sertleştirilmiş çelikler ve paslanmaz çelikler için



# WS-EBD

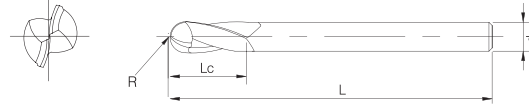

EDP No.	R	L	Lc	d	fiyat \$
W04001K	R0.05	40	0.2	4	66.22
W04002K	R0.1	40	0.4	4	61.47
W04003K	R0.15	40	0.6	4	47.28
W04004K	R0.2	40	0.8	4	44.94
W04005K	R0.25	40	1	4	44.94
W04006K	R0.3	40	1.2	4	44.94
W04007K	R0.35	40	1.4	4	44.94
W04008K	R0.4	40	1.6	4	44.94
W04009K	R0.45	40	1.8	4	44.94
W040104K	R0.5	50	2.5	4	41.38
W04010K				6	42.56
W04015K	R0.75	50	4	6	42.56
W04020K	R1	50	5	6	42.56
W04025K	R1.25	60	7	6	44.94
W04030K	R1.5	60	8	6	44.94
W04035K	R1.75	70	8	6	44.94
W04040K	R2	70	8	6	44.94
W04045K	R2.25	80	10	6	47.28
W04050K	R2.5	80	10	6	47.28
W04060K	R3	90	12	6	47.28
W04080K	R4	100	14	8	55.56
W04100K	R5	100	18	10	76.84
W04120K	R6	110	22	12	94.59

- Küresel karbür freze
- 70 HRC'ye kadar sertleştirilmiş çelikler ve paslanmaz çelikler için



# WS-EBDS

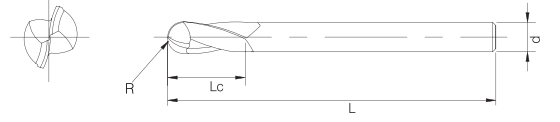

EDP No.	R	L	Lc	d	fiyat \$
W03001K	R0.05	40	0.1	6	66.22
W03002K	R0.1	40	0.2	6	63.84
W03003K	R0.15	40	0.3	6	52.03
W03004K	R0.2	40	0.4	6	49.66
W03005K	R0.25	40	0.5	6	44.94
W03006K	R0.3	40	0.6	6	44.94
W03007K	R0.35	40	0.7	6	44.94
W03008K	R0.4	40	0.8	6	44.94
W03009K	R0.45	40	0.9	6	44.94
W03010K	R0.5	40	1.5	6	37.84
W03015K	R0.75	40	2.5	6	40.19
W03020K	R1	40	3	6	37.84
W03030K	R1.5	50	4.5	6	40.19
W03040K	R2	50	6	6	42.56
W03050K	R2.5	50	7.5	6	44.94
W03060K	R3	50	9	6	47.28
W03080K	R4	50	12	8	53.19
W03100K	R5	60	15	10	68.56
W03120K	R6	60	18	12	88.66

- Küresel karbür freze
- Kısa boylu freze
- 70 HRC'ye kadar sertleştirilmiş çelikler ve paslanmaz çelikler için

# WS-LN-EBD

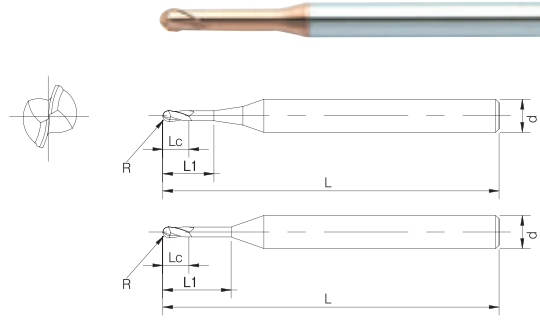

EDP No.	R	L	L <sub>1</sub>	L <sub>c</sub>	d	fiyat \$
W01001002K			0,2			66,81
W01001003K	R0,05	45	0,3	0,1	4	66,81
W01001005K			0,5			66,81
W01002006K			0,6			64,78
W01002010K	R0,2	45	1	0,2	4	64,78
W01002015K			1,5			64,78
W01003010K			1			51,41
W01003015K	R0,4	45	1,5	0,3	4	51,41
W01003020K			2			51,41
W01003030K			3			51,41
W01004010K			1			51,41
W01004015K			1,5			51,41
W01004020K			2			51,41
W01004025K	R0,2	45	2,5	0,4	4	51,41
W01004030K			3			51,41
W01004040K			4			51,41
W01004050K			5			51,41
W01005010K			1			41,13
W01005015K			1,5			41,13
W01005020K			2			41,13
W01005025K	R0,25	45	2,5	0,5	4	41,13
W01005040K			4			41,13
W01005050K			5			41,13
W01005060K			6			43,19
W01005080K			8			43,19
W01006020K			2			41,13
W01006030K			3			41,13
W01006040K			4			41,13
W01006050K	R0,3	45	5	0,6	4	41,13
W01006060K			6			41,13
W01006080K			8			43,19
W01006100K			10			43,19
W01008020K			2			41,13
W01008030K	R0,4	45	3	0,8	4	41,13
W01008040K			4			41,13

- Küresel karbür freze
- Boyunlu geometri
- 70 HRC'ye kadar sertleştirilmiş çelikler ve paslanmaz çelikler için

# WS-LN-EBD

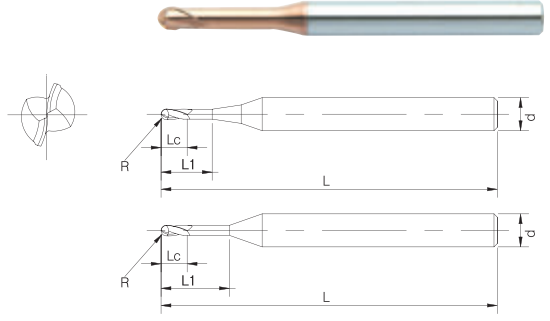

EDP No.	R	L	L <sub>1</sub>	L <sub>c</sub>	d	fiyat \$				
W01008050K	R0,4	45	5	0,8	4	41,13				
W01008060K			6			41,13				
W01008080K			8			43,19				
W01008100K			10			43,19				
W01008120K			12			43,19				
W01010030K	R0,5	50	3	1,0	4	37,00				
W01010040K			4			37,00				
W01010050K			5			37,00				
W01010060K			6			37,00				
W01010070K			7			37,00				
W01010080K			8			39,06				
W01010090K			9			39,06				
W01010100K			10			40,09				
W01010120K			12			40,09				
W01010140K			14			41,13				
W01010160K			16			41,13				
W01010200K			20			42,16				
W01012040K			R0,6			50	4	1,2	4	37,00
W01012060K							6			37,00
W01012080K							8			38,03
W01012100K	10	39,06								
W01012120K	12	40,09								
W01015040K	R0,75	50	4	1,5	4	37,00				
W01015060K			6			38,03				
W01015080K			8			39,06				
W01015100K			10			40,09				
W01015120K			12			40,09				
W01015140K			14			41,13				
W01015160K			16			41,13				
W01015200K	20	42,16								
W01020060K	R1,0	50	6	3	4	35,97				
W01020080K			8			37,00				
W01020100K			10			38,03				
W01020120K			12			39,06				
W01020140K			14			40,09				

# WS-LN-EBD

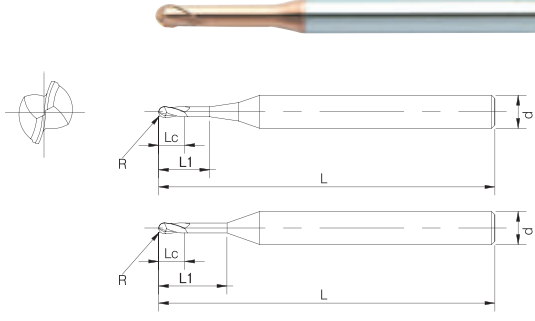

EDP No.	R	L	L <sub>1</sub>	L <sub>c</sub>	d	fiyat \$
W01020160K	R1.0	50	16	3	4	41,13
W01020180K			18			41,13
W01020200K			20			42,16
W01020250K			25			43,19
W01020300K			30			44,22
W01025080K	R1.25	55	8	3.5	4	39,06
W01025100K			10			41,13
W01030080K	R1.5	55	8	4	6	37,00
W01030100K			10			39,06
W01030120K			12			39,06
W01030140K			14			40,09
W01030160K			16			41,13
W01030180K		18	42,16			
W01030200K		60	20			43,19
W01030250K			25			44,22
W01030300K			30			46,25
W01030350K			35			48,31
W01040100K	R2.0		55	10	5	6
W01040120K		12		40,09		
W01040160K		16		41,13		
W01040200K		60	20	42,16		
W01040250K			25	44,22		
W01040300K			30	44,22		
W01040350K			35	45,22		
W01040400K			40	47,28		
W01060150K	R3	60	15	8	6	41,13
W01060300K			30			43,19
W01080150K	R4	65	15	10	8	47,28
W01080200K		80	20			49,34
W01100200K	R5	60	20	12	10	63,75
W01100250K		80	25			65,78
W01120250K	R6	80	25	14	12	82,25
W01120400K		110	40			87,38

# WS-LN-EBD-6

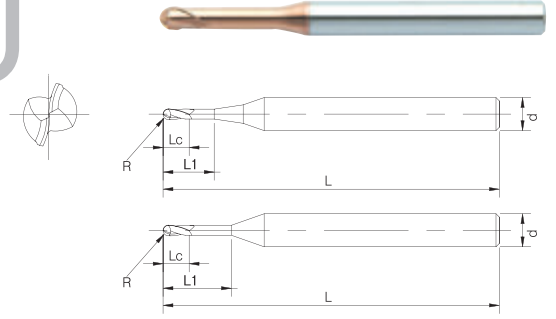

EDP No.	R	L	L <sub>1</sub>	L <sub>c</sub>	d	fiyat \$
W02006020K	R0,3	45	2	0,6	6	43,19
W02006040K			4			43,19
W02006060K			6			43,19
W02008040K	R0,4	45	4	0,8	6	43,19
W02008060K			6			43,19
W02010040K			4			1,0
W02010060K	6	41,13				
W02010080K	8	41,13				
W02010100K	10	42,16				
W02015060K	R0,75	50	6	1,5	6	38,03
W02015080K			8			39,06
W02015100K			10			40,09
W02015120K			12			41,13
W02020060K	R1,0	50	6	3	6	38,03
W02020080K			8			39,06
W02020100K			10			40,09
W02020120K			12			41,13

- Küresel karbür freze
- Boyunlu geometri
- 6 mm şaft ölçüsü
- 70 HRC'ye kadar sertleştirilmiş çelikler ve paslanmaz çelikler için

# WS-EDS

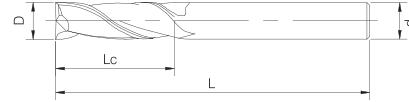
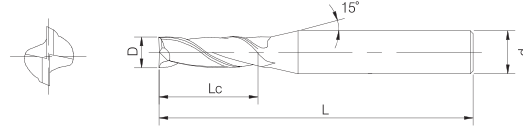

D≤6 0~0.012  
D≤6 0~0.015



SHRINK  
FIT



min<sup>-1</sup>

EDP No.	D	L	Lc	d	fiyat \$
W09001001K	0.1	40	0.1	4	44,94
W09002002K	0.2	40	0.2	4	41,38
W09003003K	0.3	40	0.3	4	36,66
W09005100K	0.5	40	1	4	31,91
W09006012K	0.6	40	1.2	4	31,91
W09007014K	0.7	40	1.4	4	31,91
W09008016K	0.8	40	1.6	4	31,91
W09009018K	0.9	40	1.8	4	31,91
W09010020K	1	50	2	6	23,66
W09015030K	1.5	50	3	6	23,66
W09020040K	2	50	4	6	23,66
W09020060K	2	50	6	6	23,66
W09025070K	2.5	50	7	6	23,66
W09030060K	3	70	6	3	26,00
W09030080K		60	8	6	26,00
W09030100K			10		26,00
W09030120K			12		26,00
W09040080K	4		80		8
W09040100K		10	4	26,00	
W09040120K		60	12	6	26,00
W09050130K	5	60	13	6	28,38
W09060150K	6	60	15	6	28,38
W09080190K	8	65	19	8	33,09
W09100250K	10	70	25	10	44,94
W09120300K	12	80	30	12	57,94

- 2 ağızlı karbür freze
- 70 HRC'ye kadar sertleştirilmiş çelikler ve paslanmaz çelikler için

# WS-LN-EDS

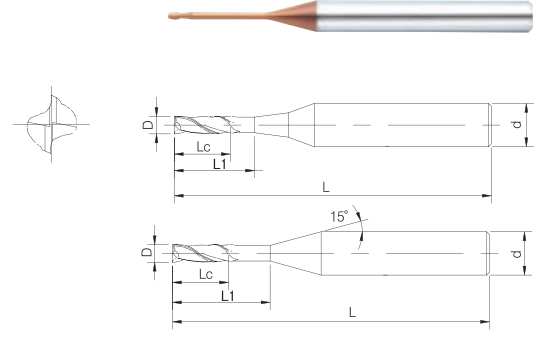

EDP No.	D	L	L <sub>1</sub>	L <sub>c</sub>	d	fiyat \$
W08001003K	0.1	45	0.3	0.15	4	51,41
W08001005K			0.5			51,41
W08002005K	0.2	45	0.5	0.3	4	46,25
W08002010K			1			46,25
W08002015K			1.5			46,25
W08003010K	0.3	45	1	0.45	4	41,13
W08003015K			1.5			41,13
W08003020K			2			41,13
W08003025K			2.5			41,13
W08003030K			3			41,13
W08003040K			4			41,13
W08003050K			5			41,13
W08004010K			0.4			45
W08004015K	1.5	41,13				
W08004020K	2	41,13				
W08004025K	2.5	41,13				
W08004030K	3	41,13				
W08004040K	4	41,13				
W08004050K	5	41,13				
W08004060K	6	41,13				
W08005010K	0.5	45	1	0.7	4	30,84
W08005015K			1.5			30,84
W08005020K			2			30,84
W08005025K			2.5			30,84
W08005040K			4			30,84
W08005050K			5			30,84
W08005060K			6			30,84
W08005080K			8			30,84
W08006020K	0.6	45	2	0.9	4	30,84
W08006030K			3			30,84
W08006040K			4			30,84
W08006050K			5			30,84
W08006060K			6			30,84
W08006080K			8			31,88
W08006100K	10	31,88				

- 2 ağızlı karbür freze
- Boyunlu geometri
- 70 HRC'ye kadar sertleştirilmiş çelikler ve paslanmaz çelikler için

# WS-LN-EDS

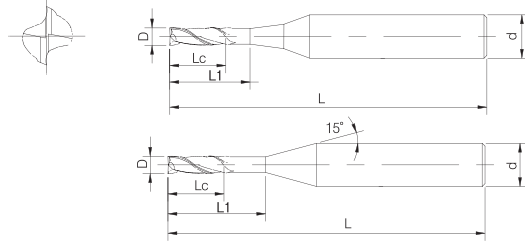

EDP No.	D	L	L <sub>1</sub>	L <sub>c</sub>	d	fiyat \$
W08007040K	0.7	45	4	1.2	4	31.88
W08007060K			6			31.88
W08008020K	0.8	45	2	1.2	4	31.88
W08008030K			3			31.88
W08008040K			4			31.88
W08008050K			5			31.88
W08008060K			6			31.88
W08008080K			8			31.88
W08008100K			10			31.88
W08008120K			12			31.88
W08010030K	1	50	3	1.5	4	23.66
W08010040K			4			27.75
W08010050K			5			27.75
W08010060K			6			27.75
W08010080K			8			27.75
W08010100K			10			27.75
W08010120K			12			28.78
W08010140K			14			28.78
W08010160K			16			28.78
W08010200K			20			28.78
W08012040K	1.2	50	4	1.8	4	23.66
W08012060K			6			23.66
W08012080K			8			28.78
W08012100K			10			28.78
W08012120K			12			29.81
W08015040K	1.5	50	4	2.3	4	23.66
W08015060K			6			28.78
W08015080K			8			28.78
W08015100K			10			28.78
W08015120K			12			29.81
W08015140K			14			29.81
W08015160K			16			29.81
W08015180K			18			30.84
W08015200K	20	30.84				
W08020060K	2	50	6	3	4	23.66



# WS-LN-EDS

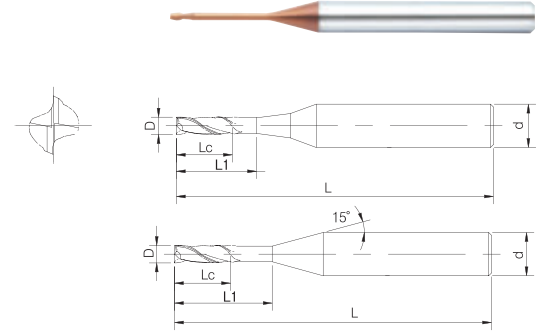

EDP No.	D	L	L <sub>1</sub>	L <sub>c</sub>	d	fiyat \$
W08020080K	2	50	8	3	4	28.78
W08020100K			10			28.78
W08020120K			12			29.81
W08020140K			14			29.81
W08020160K			16			29.81
W08020180K		55	18			30.84
W08020200K			20			30.84
W08020250K			25			32.91
W08020300K			30			34.97
W08025080K			2.5			50
W08025100K	10	30.84				
W08030080K	3	55	8	4.5	6	30.84
W08030100K			10			30.84
W08030120K			12			31.88
W08030140K			14			31.88
W08030160K			16			31.88
W08030180K		60	18			32.91
W08030200K			20			32.91
W08030250K			25			33.94
W08030300K			30			34.97
W08030350K			35			35.97
W08030400K	40	37.00				
W08040100K	4	55	10	6.0	6	24.69
W08040120K			12			31.88
W08040160K			16			31.88
W08040200K		60	20			32.91
W08040250K			25			32.91
W08040300K			30			34.97
W08040350K			35			37.00
W08040400K		40	39.06			

# WS-EMS

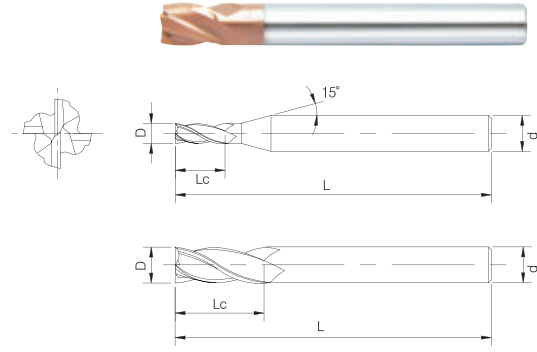

ULTRAFINE  
CARBIDE

WS



D≤6 0~0.012  
D≤6 0~0.015



SHRINK  
FIT



30°

min<sup>-1</sup>

EDP No.	D	L	Lc	d	fiyat \$
W 1 1 0 1 0 K	1	50	2,5	6	30,75
W 1 1 0 1 2 K	1,2	50	3	6	33,09
W 1 1 0 1 5 K	1,5	50	4	6	30,75
W 1 1 0 2 0 K	2	50	6	6	33,09
W 1 1 0 2 5 K	2,5	50	7	6	33,09
W 1 1 0 3 0 K	3	60	8	6	34,28
W 1 1 0 3 5 K	3,5	60	9	6	34,28
W 1 1 0 4 0 K	4	60	10	6	34,28
W 1 1 0 5 0 K	5	60	13	6	36,66
W 1 1 0 6 0 K	6	60	15	6	36,66
W 1 1 0 8 0 K	8	65	19	8	41,38
W 1 1 1 0 0 K	10	70	25	10	53,19
W 1 1 1 2 0 K	12	80	30	12	62,66

- Çok ağızlı karbür freze
- 70 HRC'ye kadar sertleştirilmiş çelikler ve paslanmaz çelikler için

# WS-LN-EMS

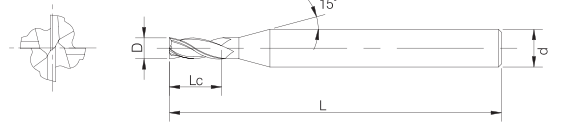

EDP No.	D	L	L <sub>1</sub>	L <sub>c</sub>	d	fiyat \$
W10010030K	1	50	3	1.5	4	28,78
W10010040K			4			28,78
W10010060K			6			28,78
W10010080K			8			28,78
W10010100K			10			28,78
W10010120K			12			29,81
W10015040K	1.5	50	4	2.3	4	28,78
W10015060K			6			30,84
W10015080K			8			30,84
W10015100K			10			30,84
W10015120K	12	31,88				
W10020060K	2	50	6	3	4	28,78
W10020080K			8			28,78
W10020100K			10			28,78
W10020120K			12			29,81
W10020160K			16			30,84
W10020200K			20			31,88
W10030100K	3	55	10	5.5	6	29,81
W10030120K			12			30,84
W10030160K			16			31,88
W10030200K			20			32,91
W10040120K	4	55	12	6	6	29,81
W10040160K			16			30,84
W10040200K		60	20			31,88
W10040250K			25			33,94
W10060200K	6	80	20	9	6	34,97
W10060300K	8	80	30	12	8	37,00
W10080400K		100	40			41,13
W10100350K	10	80	35	15	10	49,34
W10100450K		100	45			51,41
W10120400K		12	100			40

- Çok ağızlı karbür freze
- Boyunlu geometri
- 70 HRC'ye kadar sertleştirilmiş çelikler ve paslanmaz çelikler için

# WS-LN-CR-EDS

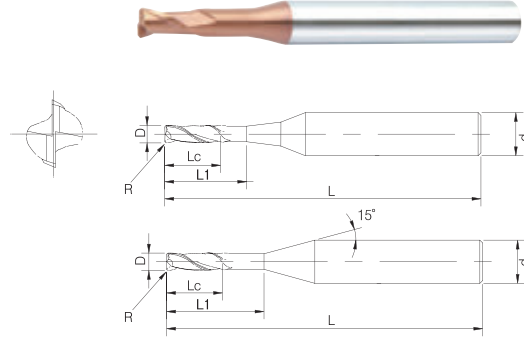

D≤6 0~-0,012  
D≤6 0~-0,015



EDP No.	D	L	L <sub>1</sub>	R	L <sub>c</sub>	d	fiyat \$
W05004010005K	0,4	45	1	R0,05	0,6	4	41,13
W05004015005K			1,5				41,13
W05004025005K			2,5				41,13
W05004030005K			3				41,13
W05004040005K			4				41,13
W05005010005K	0,5	45	1	R0,05	0,7	4	35,97
W05005015005K			1,5				35,97
W05005025005K			2,5				35,97
W05005030005K			3				35,97
W05005040005K			4				35,97
W05006020005K	0,6	45	2	R0,05	0,9	4	35,97
W05006040005K			4				35,97
W05006060005K			6				35,97
W05006020010K			2	R0,1			35,97
W05006040010K			4				35,97
W05006060010K			6				35,97
W05006020020K			2	R0,2			35,97
W05006040020K			4				35,97
W05006060020K			6				35,97
W05008020005K			2				R0,05
W05008040005K	4	33,94					
W05008060005K	6	33,94					
W05008080005K	8	34,97					
W05008020010K	2	R0,1	33,94				
W05008040010K	4		33,94				
W05008060010K	6		33,94				
W05008080010K	8	R0,2	33,94				
W05008020020K	2		33,94				
W05008040020K	4		33,94				
W05008060020K	6		34,97				
W05008080020K	8	34,97					
W05010030005K	1	50	3	R0,05	2	4	30,84
W05010040005K			4				30,84
W05010060005K			6				30,84
W05010080005K			8				30,84

- 2 ağızlı karbür freze
- Boyunlu geometri
- Köşe radyuslu freze
- 70 HRC'ye kadar sertleştirilmiş çelikler ve paslanmaz çelikler için

# WS-LN-CR-EDS

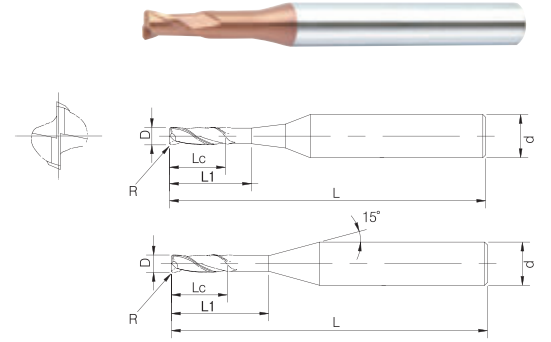

D≤6 0~0.012  
D≤6 0~0.015



EDP No.	D	L	L <sub>1</sub>	R	L <sub>c</sub>	d	fiyat \$
W05010100005K	1	50	10	R0.05	2	4	31.88
W05010030010K			3	R0.1			30.84
W05010040010K			4				30.84
W05010060010K			6				30.84
W05010080010K			8				30.84
W05010100010K			10				31.88
W05010030020K			3	R0.2			30.84
W05010040020K			4				30.84
W05010060020K			6				30.84
W05010080020K			8				30.84
W05010100020K			10				31.88
W05010030030K			3	R0.3			30.84
W05010040030K			4				30.84
W05010060030K			6				30.84
W05010080030K			8				30.84
W05010100030K	10	31.88					
W05015040005K	1.5	50	4	R0.05	2.5	4	30.84
W05015060005K			6				30.84
W05015080005K			8				30.84
W05015100005K			10				31.88
W05015120005K			12				31.88
W05015040010K			4	R0.1			30.84
W05015060010K			6				30.84
W05015080010K			8				30.84
W05015100010K			10				31.88
W05015120010K			12				31.88
W05015040020K			4	R0.2			30.84
W05015060020K			6				30.84
W05015080020K			8				30.84
W05015100020K			10				31.88
W05015120020K			12				31.88
W05015040030K	4	R0.3	30.84				
W05015060030K	6		30.84				
W05015080030K	8		30.84				
W05015100030K	10		31.88				
W05015120030K	12		31.88				

# WS-LN-CR-EDS

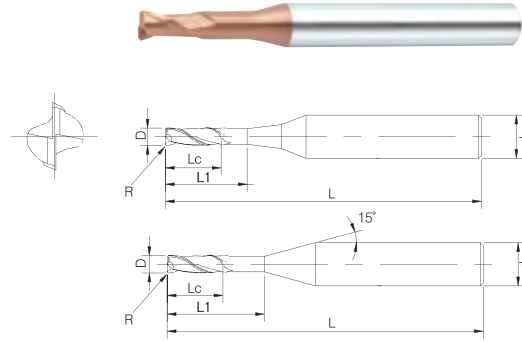

D≤6 0<sup>-</sup>→-0.012  
D≤6 0<sup>-</sup>→-0.015



EDP No.	D	L	L <sub>1</sub>	R	L <sub>c</sub>	d	fiyat \$			
W05015120030K	1.5	50	12	R0,3	2.5	4	31,88			
W05015040050K			4	R0,5			30,84			
W05015060050K			6				30,84			
W05015080050K			8				30,84			
W05015100050K			10				31,88			
W05015120050K			12				31,88			
W05020060010K	2	50	6	R0,1	3	4	30,84			
W05020080010K			8				30,84			
W05020100010K			10				31,88			
W05020120010K			12				31,88			
W05020160010K			16				31,88			
W05020200010K			20				31,88			
W05020060020K			6	R0,2			3	30,84		
W05020080020K			8					30,84		
W05020100020K			10					31,88		
W05020120020K			12					31,88		
W05020160020K			16					31,88		
W05020200020K			20					31,88		
W05020060030K			6	R0,3				3	30,84	
W05020080030K			8						30,84	
W05020100030K			10						31,88	
W05020120030K			12						31,88	
W05020160030K			16						31,88	
W05020200030K			20						31,88	
W05020060050K			6	R0,5					3	30,84
W05020080050K			8							30,84
W05020100050K	10	31,88								
W05020120050K	12	31,88								
W05020160050K	16	31,88								
W05020200050K	20	31,88								
W05025080020K	2.5	55	8	R0,2	3.5	4				32,91
W05025100020K			10							33,94
W05025120020K			12				33,94			
W05025160020K			16				33,94			
W05025080030K			8	R0,3			32,91			

# WS-LN-CR-EDS

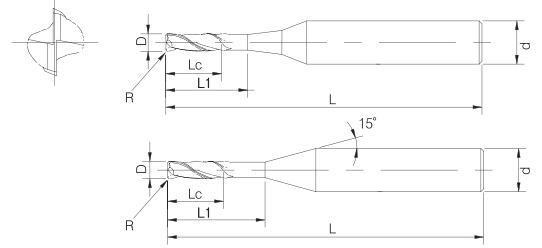

EDP No.	D	L	L <sub>1</sub>	R	L <sub>c</sub>	d	fiyat \$	
W05025100030K	2.5	55	10	R0.3	3.5	4	33,94	
W05025120030K			12				33,94	
W05025160030K			16				33,94	
W05025080050K			8				32,91	
W05025100050K			10	R0.5			33,94	
W05025120050K			12				33,94	
W05025160050K			16				33,94	
W05030080010K			8				32,91	
W05030100010K	55	10	R0.1	33,94				
W05030120010K		12		33,94				
W05030160010K		16		33,94				
W05030200010K		20		33,94				
W05030080020K	55	8	R0.2	32,91				
W05030100020K		10		33,94				
W05030120020K		12		33,94				
W05030160020K		16		33,94				
W05030200020K	60	20	33,94					
W05030080030K	3	55	8	R0.3	4.5	6	32,91	
W05030100030K			10				33,94	
W05030120030K			12				33,94	
W05030160030K			16				33,94	
W05030200030K			60	20			33,94	
W05030080050K			55	8			R0.5	32,91
W05030100050K				10				33,94
W05030120050K				12				33,94
W05030160050K	16	33,94						
W05030200050K	60	20	33,94					
W05030080100K	55	8	R1.0	32,91				
W05030100100K		10		33,94				
W05030120100K		12		33,94				
W05030160100K		16		33,94				
W05030200100K	60	20	33,94					
W05040100010K	4	55	10	R0.1	6	6	33,94	
W05040120010K			12				33,94	
W05040160010K			16				33,94	

# WS-LN-CR-EDS

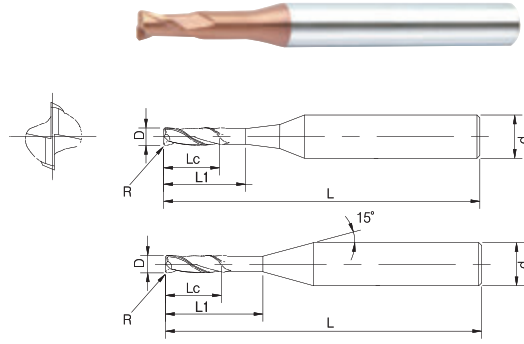

D≤6 0~0.012  
D≤6 0~0.015



EDP No.	D	L	L <sub>1</sub>	R	L <sub>c</sub>	d	fiyat \$	
W05040200010K	4	60	20	R0.1	6	6	33,94	
W05040250010K			25				33,94	
W05040100020K			55	10			R0.2	33,94
W05040120020K				12				33,94
W05040160020K		60	16	33,94				
W05040200020K			20	33,94				
W05040250020K		25	33,94					
W05040100030K		55	10	R0.3			33,94	
W05040120030K			12				34,97	
W05040160030K			16				34,97	
W05040200030K			20				34,97	
W05040250030K		60	25	34,97				
W05040100050K		55	10	R0.5			33,94	
W05040120050K			12				34,97	
W05040160050K			16				34,97	
W05040200050K			20				34,97	
W05040250050K		60	25	34,97				
W05040100100K		55	10	R1.0			33,94	
W05040120100K			12				34,97	
W05040160100K			16				34,97	
W05040200100K	20		34,97					
W05040250100K	60	25	34,97					
W05060150020K	6	60	15	R0.2	9	6	33,94	
W05060150030K			R0.3	33,94				
W05060150050K			R0.5	33,94				
W05060150100K			R1.0	33,94				
W05060150150K			R1.5	33,94				
W05060150200K			R2.0	33,94				
W05080200020K	8	65	20	R0.2	12	8	37,00	
W05080200030K				R0.3			37,00	
W05080200050K				R0.5			37,00	
W05080200100K				R1.0			37,00	
W05080200150K				R1.5			37,00	
W05100250020K	10	70	25	R0.2	15	10	49,34	
W05100250030K				R0.3			49,34	



# WS-LN-CR-EDS

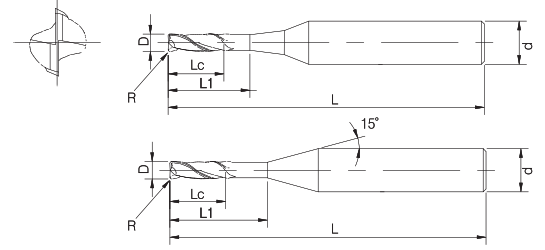

EDP No.	D	L	L <sub>1</sub>	R	L <sub>c</sub>	d	fiyat \$
W05100250050K	10	70	25	R0,5	15	10	49,34
W05100250100K				R1,0			49,34
W05100250150K				R1,5			49,34
W05100250200K				R2,0			49,34
W05120300030K	12	80	30	R0,3	18	12	64,78
W05120300050K				R0,5			64,78
W05120300100K				R1,0			64,78
W05120300150K				R1,5			64,78
W05120300200K				R2,0			64,78

# WS-LN-CR-EMS

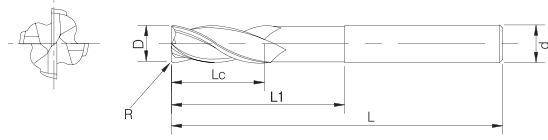

D≤6 0~-0.012  
D≤6 0~-0.015



EDP No.	D	L	L <sub>1</sub>	R	L <sub>c</sub>	d	fiyat \$				
W06020060010K	2	50	6	R0.1	3	4	35,97				
W06020080010K			8				35,97				
W06020060020K			6	R0.2			35,97				
W06020080020K			8				35,97				
W06020060030K			6	R0.3			35,97				
W06020080030K			8				35,97				
W06020060050K			6	R0.5			35,97				
W06020080050K			8				35,97				
W06030080020K			3	55			8	R0.2	4	6	37,00
W06030100020K							10				37,00
W06030120020K	12	38,03									
W06030160020K	16	39,06									
W06030200020K	60	20		R0.3	4	6	41,13				
W06030080030K	55	8					38,03				
W06030100030K		10					38,03				
W06030120030K		12					38,03				
W06030160030K		16		39,06							
W06030200030K	60	20		R0.5	4	6	40,09				
W06030080050K	55	8					38,03				
W06030100050K		10					38,03				
W06030120050K		12					39,06				
W06030160050K		16		39,06							
W06030200050K	60	20		R1.0	4	6	39,06				
W06030100100K	55	10					38,03				
W06030120100K		12					39,06				
W06030160100K		16					39,06				
W06040100010K		4		55	10	R0.1	6	6			38,03
W06040120010K	12				39,06						
W06040160010K	16		39,06								
W06040200010K	60		20		R0.2				6	6	40,09
W06040100020K	55		10	40,09							
W06040120020K			12	38,03							
W06040160020K			16	39,06							
W06040200020K			60	20	R0.3	6			6	39,06	
W06040100030K	55		10	40,09							

- Çok ağızlı karbür freze
- Boyunlu geometri
- Köşe radyuslu freze
- 70 HRC'ye kadar sertleştirilmiş çelikler ve paslanmaz çelikler için

# WS-LN-CR-EMS

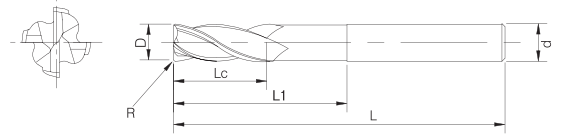

EDP No.	D	L	L <sub>1</sub>	R	L <sub>c</sub>	d	fiyat \$					
W06040120030K	4	55	12	R0.3	6	6	38,03					
W06040160030K			16				39,06					
W06040200030K			20				40,09					
W06040250030K			25				40,09					
W06040120050K		55	60	12			R0.5	6	6	38,03		
W06040160050K				16						39,06		
W06040200050K				20						40,09		
W06040250050K				25						40,09		
W06040100100K		55	60	10			R1.0			6	6	38,03
W06040120100K				12								39,06
W06040160100K				16								40,09
W06040200100K				20								39,06
W06060150020K	6	60	15	R0.2	9	6	39,06					
W06060150030K				R0.3			39,06					
W06060150050K				R0.5			39,06					
W06060150100K				R1.0			39,06					
W06080200020K	8	70	20	R0.2	12	8	44,22					
W06080200030K				R0.3			45,22					
W06080200050K				R0.5			45,22					
W06080200100K				R1.0			45,22					
W06100250020K	10	70	25	R0.2	15	10	59,63					
W06100250030K				R0.3			59,63					
W06100250050K				R0.5			59,63					
W06100250100K				R1.0			59,63					
W06120300050K	12	80	30	R0.5	18	12	80,19					
W06120300100K				R1.0			80,19					

# WS-PHS

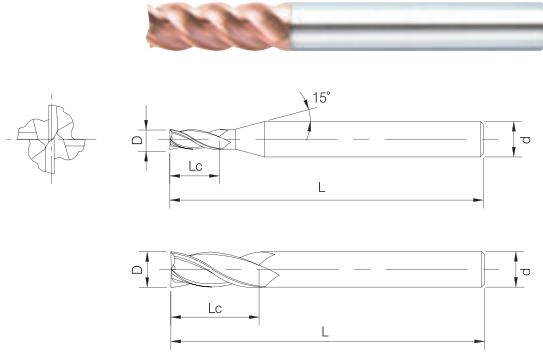

EDP No.	D	L	Lc	d	fiyat \$
W07030K	3	60	8	6	42,56
W07040K	4	60	11	6	42,56
W07050K	5	60	13	6	46,09
W07060K	6	60	13	6	46,09
W07080K	8	80	19	8	52,03
W07100K	10	80	22	10	67,38
W07120K	12	100	26	12	78,03
W07160K	16	115	32	16	190,34
W07200K	20	125	38	20	262,47

- 4 ağızlı karbür freze
- 70 HRC'ye kadar sertleştirilmiş çelikler ve paslanmaz çelikler için

# WS-PKE

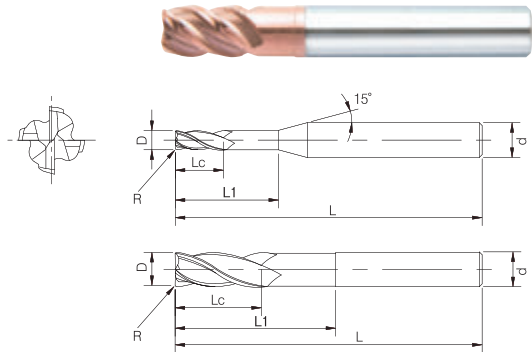

EDP No.	D	L	L1	R	Lc	d	fiyat \$
W13030020K	3	50	12	R0,2	5	6	44,94
W13030050K				R0,5			44,94
W13040020K	4	50	16	R0,2	6	6	46,09
W13040050K				R0,5			46,09
W13050020K	5	50	16	R0,2	8	6	46,09
W13050050K				R0,5			46,09
W13060050K	6	50	20	R0,5	9	6	49,66
W13060100K				R1			49,66
W13080050K	8	60	20	R0,5	12	8	54,38
W13080100K				R1			54,38
W13100050K	10	70	25	R0,5	15	10	76,84
W13100100K				R1			76,84
W13120050K	12	80	20	R0,5	18	12	89,84
W13120100K				R1			89,84

- 4 ağızlı karbür freze
- 70 HRC'ye kadar sertleştirilmiş çelikler ve paslanmaz çelikler için

# WS-LS-PKE

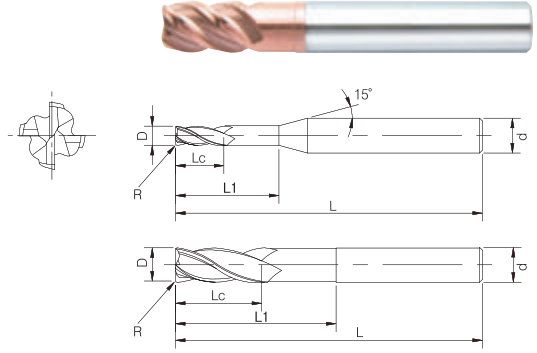

EDP No.	D	L	L <sub>1</sub>	R	L <sub>c</sub>	d	fiyat \$
W14040020K	4	70	20	R0,2	6	6	57,94
W14040050K				R0,5			57,94
W14050020K	5	80	25	R0,2	8	6	57,94
W14050050K				R0,5			57,94
W14060050K	6	90	30	R0,5	9	6	61,47
W14060100K				R1			61,47
W14080050K	8	100	40	R0,5	12	8	68,56
W14080100K				R1			68,56
W14100050K	10	100	40	R0,5	15	10	95,75
W14100100K				R1			95,75
W14120050K	12	110	50	R0,5	18	12	111,13
W14120100K				R1			111,13

- 4 ağızlı karbür freze
- Uzun boylu freze
- Köşe radyuslu freze
- 70 HRC'ye kadar sertleştirilmiş çelikler ve paslanmaz çelikler için

# WS-CRE

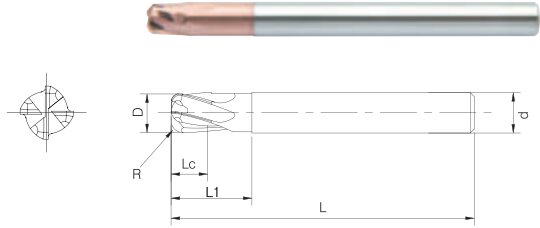

EDP No.	D	L	L <sub>1</sub>	R	L <sub>c</sub>	d	fiyat \$
W12020050K	2	50	6	R0,5	2	6	60,28
W12030050K	3	50	7,5	R0,5	3	6	63,84
W12040050K	4	50	10	R0,5	4	6	63,84
W12040100K				R1			63,84
W12050100K	5	50	10	R1	5	6	69,75
W12050150K				R1,5			69,75
W12060100K	6	50	12	R1	6	6	69,75
W12060150K				R1,5			69,75
W12080100K	8	60	16	R1	8	8	79,22
W12080150K				R2			79,22
W12100100K	10	70	20	R1	10	10	100,50
W12100200K				R2			100,50
W12120200K	12	75	24	R2	12	12	117,03
W12120300K				R3			117,03

- 4 ağızlı karbür freze
- 15 derece helis açısı
- Köşe radyuslu freze
- Yüksek hızlı işlemler için (high feed)
- 70 HRC'ye kadar sertleştirilmiş çelikler ve paslanmaz çelikler için

# SUS SERİLERİ

- Paslanmaz için karbür frezeler



# S-VCM

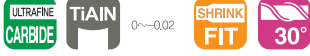
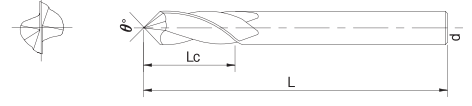

EDP No.	D	L	θ	Lc	d	fiyat \$
8003060K	3	50	60°	6	6	30,84
8003090K			90°			30,84
8003120K			120°			30,84
8004060K	4	50	60°	8	6	33,56
8004090K			90°			33,56
8004120K			120°			33,56
8005060K	5	55	60°	10	6	33,56
8005090K			90°			33,56
8005120K			120°			33,56
8006060K	6	60	60°	12	6	45,66
8006090K			90°			45,66
8006120K			120°			45,66
8007090K	7	65	90°	14	8	57,75
8008060K	8	70	60°	16	8	69,88
8008090K			90°			69,88
8008120K			120°			69,88
8009090K	9	75	90°	18	10	76,19
8010060K	10	80	60°	20	10	82,50
8010090K			90°			82,50
8010120K			120°			82,50
8012060K	12	90	60°	24	12	98,19
8012090K			90°			98,19
8012120K			120°			98,19

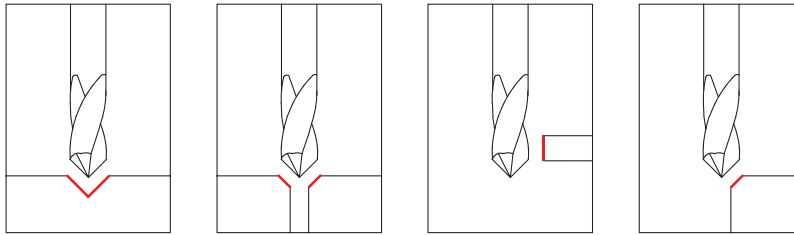

- Pah takımı
- Karbür

# SUS-PMS

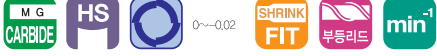
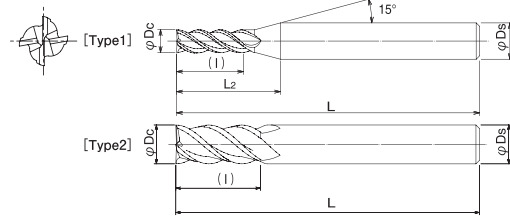

EDP No.	D	F	L	Lc	d	fiyat \$
T 4 P 0 1 0	1.0	4F	50	2,5	6	26,22
T 4 P 0 1 5	1.5	4F	50	4	6	26,88
T 4 P 0 2 0	2.0	4F	50	6	6	27,56
T 4 P 0 2 5	2.5	4F	50	7	6	28,22
T 4 P 0 3 0	3.0	4F	55	8	6	29,59
T 4 P 0 4 0	4.0	4F	55	10	6	30,91
T 4 P 0 5 0	5.0	4F	55	15	6	30,91
T 4 P 0 6 0	6.0	4F	60	15	6	30,56
T 4 P 0 7 0	7.0	4F	70	20	8	38,47
T 4 P 0 8 0	8.0	4F	70	20	8	38,47
T 4 P 1 0 0	10.0	4F	75	25	10	53,16
T 4 P 1 2 0	12.0	4F	80	30	12	68,19
T 4 P 1 6 0	16.0	4F	100	42	16	168,47
T 4 P 2 0 0	20.0	4F	100	48	20	253,69

- Çok ağızlı karbür freze
- Paslanmaz malzemeler için



# SUS-CR-PMS

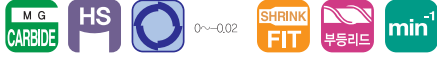
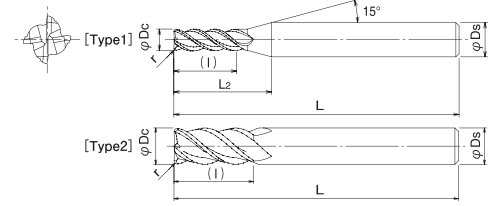

EDP No.	D	R	F	L	Lc	d	fiyat \$
T4PC 010 010	1	R0.1	4F	50	2.5	6	28,84
T4PC 010 020		R0.2	4F	50	2.5	6	28,84
T4PC 015 010	1.5	R0.1	4F	50	4	6	30,09
T4PC 015 020		R0.2	4F	50	4	6	30,09
T4PC 020 010	2	R0.1	4F	50	6	6	30,31
T4PC 020 020		R0.2	4F	50	6	6	30,31
T4PC 025 020	2.5	R0.2	4F	50	7	6	31,03
T4PC 030 020	3	R0.2	4F	55	8	6	32,53
T4PC 030 030		R0.3	4F	55	8	6	32,53
T4PC 030 050		R0.5	4F	55	8	6	32,53
T4PC 040 020	4	R0.2	4F	55	10	6	34,00
T4PC 040 050		R0.5	4F	55	10	6	34,00
T4PC 050 020	5	R0.2	4F	55	15	6	36,22
T4PC 050 050		R0.5	4F	55	15	6	36,22
T4PC 050 100		R1.0	4F	55	15	6	36,22
T4PC 060 050	6	R0.5	4F	60	15	6	36,22
T4PC 060 100		R1.0	4F	60	15	6	36,22
T4PC 030 030	7	R1.5	4F	60	15	6	36,22
T4PC 070 030		R0.3	4F	70	20	8	46,19
T4PC 080 020		R0.2	4F	70	20	8	46,19
T4PC 080 030		R0.3	4F	70	20	8	46,19
T4PC 080 050		R0.5	4F	70	20	8	46,19
T4PC 080 100		R1.0	4F	70	20	8	46,19
T4PC 080 150		R1.5	4F	70	20	8	46,19
T4PC 080 200	8	R2.0	4F	70	20	8	46,19
T4PC 100 030		R0.3	4F	75	25	10	63,75
T4PC 100 050	10	R0.5	4F	75	25	10	63,75
T4PC 100 100		R1.0	4F	75	25	10	63,75
T4PC 100 150		R1.5	4F	75	25	10	63,75
T4PC 100 200		R2.0	4F	75	25	10	63,75
T4PC 100 300		R3.0	4F	75	25	10	63,75
T4PC 120 030	12	R0.3	4F	80	30	12	81,59
T4PC 120 050		R0.5	4F	80	30	12	81,59
T4PC 120 100		R1.0	4F	80	30	12	81,59
T4PC 120 150		R1.5	4F	80	30	12	81,59
T4PC 120 200		R2.0	4F	80	30	12	81,59
T4PC 120 300		R3.0	4F	80	30	12	81,59
T4PC 160 050	16	R0.5	4F	100	42	16	193,72
T4PC 160 100		R1.0	4F	100	42	16	193,72
T4PC 200 050	20	R0.5	4F	100	48	20	279,06
T4PC 200 100		R1.0	4F	100	48	20	279,06

- Çok ağızlı karbür freze
- Köşe radyuslu freze
- Paslanmaz malzemeler için



# GS SERİLERİ AL SERİLERİ WS SERİLERİ CRN SERİLERİ SUS SERİLERİ

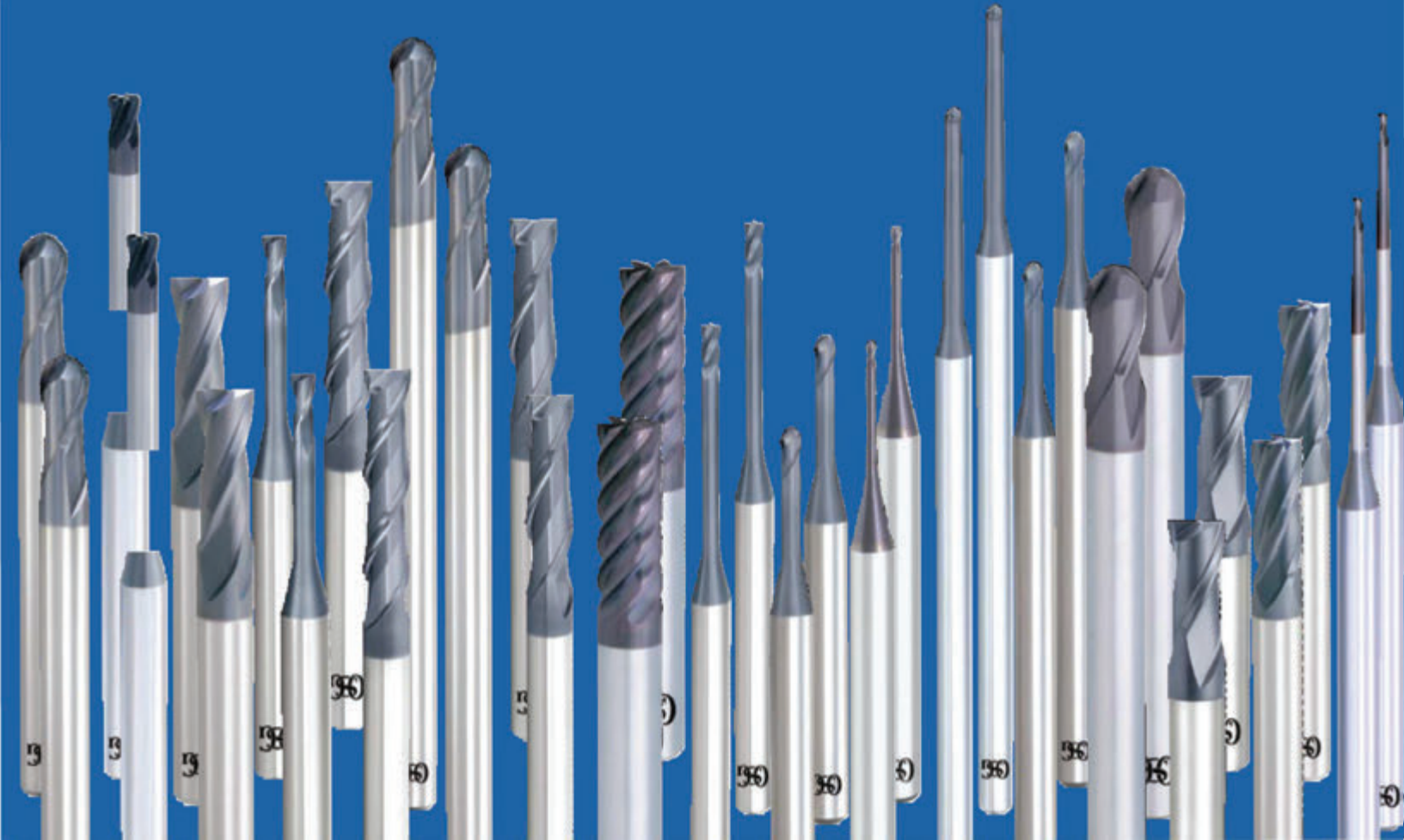



***shaping your dreams***

**OSG Turkey Kesici Takımlar San. İç ve Dış Tic.A.Ş.**

**Topçular Mah. Rami Kışla Cad. No:56 Eyüpsultan/İstanbul**

**Tel. +90 212 5652400 / +90 212 2227902**

**Fax +90 212 5654400 / +90 212 2227621**

**<http://tr.osgeurope.com>**

**[info@osg-turkey.com](mailto:info@osg-turkey.com)**